

ENGLISH

West Marine

VHF600



DSC Fixed Mount Marine Radio

Maritime Radio Services Operation

Warning!

This transmitter will operate on channels/frequencies that have restricted use in the United States. The channel assignments include frequencies assigned for exclusive use of the U.S. Coast Guard, use in Canada, and use in international waters. Operation in these frequencies without proper authorization is strictly forbidden. For frequencies/channels that are currently for use in the U.S. without an individual license, please contact the FCC Call Center at 1-888-CALL-FCC.

For individuals requiring a license, such as commercial users, you should obtain a license application from your nearest FCC field office.

West Marine works to reduce lead content in our PVC coated cords in our products and accessories.

Warning!

The cords on this product and/or accessories contain lead, a chemical known to the State of California to cause birth defects or other reproductive harm. *Wash hands after handling.*

Contents

About Your VHF600.....	2
Included With Your VHF600	3
Controls and Indicators.....	4
Installation.....	8
Choosing a Location.....	8
Engine Noise Suppression	9
Antenna Considerations	9
Antenna Selection and Installation	9
Installing the VHF600	10
Operation	11
Power On/Off	11
Last Channel Memory.....	11
Squelch.....	12
Instant Channel 16/Channel 9 Communications.....	13
Marine Distress Procedure	13
Triple Watch.....	14
Manually Selecting a Channel.....	14
Weather Channels	15
Entering Channel Numbers into Memory Scan.....	15
Memory Channel Scan.....	16
Triple Watch Alert Scan	16
Alert Scan	16
Hail	17
Adjusting the Hail Volume	17
Weather Alert.....	18
About S.A.M.E. Weather Alert.....	18
Setting Transmit (TX) Power	20
Setting TX Output.....	20
Sending a Distress Call	21
Using the Menu	22
Menu Flow Chart	22
Selecting Items From The Menu	22
Using Digital Selective Calling (DSC)	23
Individual	24
Group.....	25
All Ships Call	26
Position Request	27
Position Send	28
Standby	30
Call Wait	31
Using Setup.....	33
Alarm Clock	33

Setting the Alarm.....	33
Turning the Alarm On.....	34
Turning the Alarm Off.....	35
Adjusting the Time.....	36
Setting Daylight Saving Time.....	37
Setting Up the Directory.....	38
Entering New Information.....	39
Editing Existing Information.....	41
Deleting Information.....	43
Selecting a FIPS Code.....	44
Registering a New FIPS Code.....	45
Editing a FIPS Code.....	46
Deleting a FIPS Code.....	47
Auto Channel Switch.....	49
Position Reply.....	50
Channel Name (CH Tag).....	52
Editing a Channel Name.....	52
Defaulting a Channel Name.....	54
Setting Up a U.I.C.	55
Setting Up a WHAM (Wireless Handheld Access Microphone).....	56
Setting a Base ID.....	57
Changing the Link Channel.....	58
Setting Up a Group MMSI (Marine Mobile Service Identity).....	59
Setting Up a User MMSI.....	60
Setting Up The System.....	62
Setting the Contrast.....	62
Setting the Backlight.....	63
Setting the Key Beep.....	64
Reviewing Channel Memory.....	65
NMEA Technical Setup.....	66
Connecting a GPS Receiver to the Radio.....	66
Optional Accessories.....	66
VHF FM Marine Radio Telephone Channel and Functions.....	67
USA Channels.....	67
International Channels.....	68
Canadian Channels.....	69
NWR-SAME Event Codes.....	70
Specifications.....	71
Troubleshooting.....	72
Care and Maintenance.....	74
Three Year Limited Warranty.....	76

About Your VHF600

Your West Marine **VHF600** marine radio is a potent combination of high technology fused with rugged durability. The radio's all solid-state design and conservatively-rated components and materials make it an ideal choice for harsh marine environments.

The radio is constructed to be well-protected from the elements and meets the stringent JIS7 waterproof specification. You can use an optional flush mount (600 FMB) to mount the radio for maximum convenience aboard your vessel.

The radio's built-in DSC (Digital Selective Calling) options let you send a distress message in an emergency situation, and send and receive position data to and from other vessels. The radio's built-in weather alert function helps you stay abreast of the latest weather conditions. You can even connect an optional GPS receiver to the radio to help keep track of your current location with space-age precision.

You should read the rest of this Operating Guide thoroughly to acquaint yourself with all of your radio's features and functions.

Save your receipt as proof-of-purchase in case you ever need to have warranty service on the radio.

Features, specifications, and availability of optional accessories are all subject to change without notice.

Note: Your radio meets JIS7 requirements. This means that the radio and microphone can be submerged to a depth of 1 meter for up to 30 minutes without incurring damage.

Included With Your VHF600



VHF600 Owner's Manual

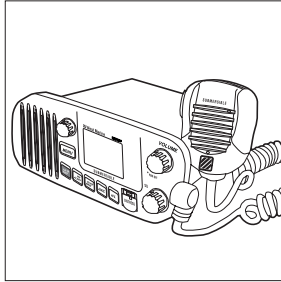

VHF600 Radio

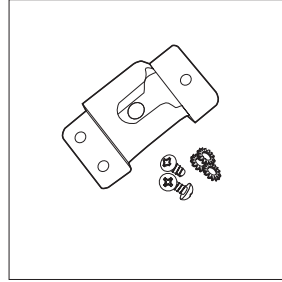

Microphone Hanger
and Screws

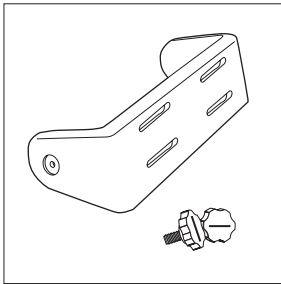

Mounting Bracket
and Knobs

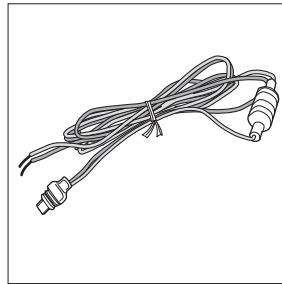

DC Cord

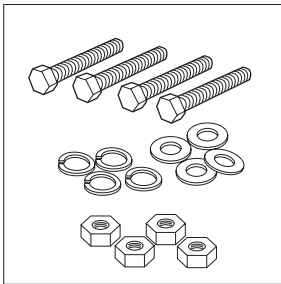

Mounting Hardware

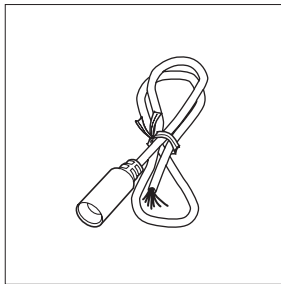

Accessory Cable

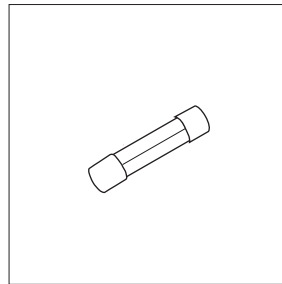

Spare Fuse
250V 6A

Controls and Indicators

Front Panel/Microphone

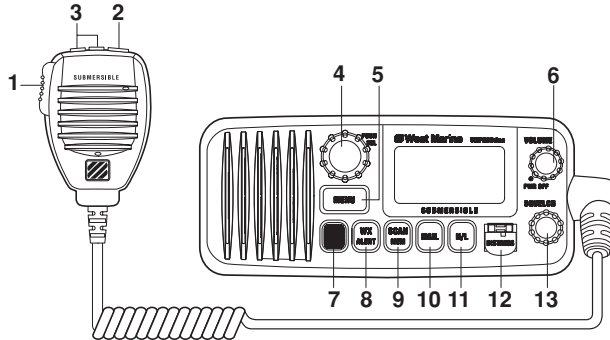

1. **PTT Switch** - Press to transmit and release to receive.
- 2,7. **16/9/TRI** - Press briefly to instantly change to Channel 16, Channel 9 or the current channel. Press for more than two seconds to activate the Triple Watch Feature.
3. **+/-** - These keys are used to change the channel number up or down. They are also used to adjust the outgoing volume for Hail mode and to move the cursor in Menu mode.
4. **PUSH/SEL** - This is used to manually select the desired Communication Channel (01-28 and 60-88), or Weather Channel (0-9). In the Menu mode this is used to select the menu options. It is also used to display the GPS mode and to adjust the outgoing volume for the HAIL mode.
5. **MENU** - Press briefly to enter the Menu mode.
6. **PWR(Power)/VOLUME (On/Off/Volume)** - Turns the unit on or off and adjusts the speaker volume.
8. **WX/ALERT** - Selects Weather channel and Weather Alert mode. Press briefly to listen to active NOAA Weather channels. Press and hold for 2 seconds to set the radio to its Weather Alert mode.
9. **SCAN/MEM** - Press briefly to activate the memory channel scan feature. Press for more than two seconds to place the currently selected channel into memory. Press for more than two seconds again to delete a channel from scanning memory.
10. **HAIL** - Use as a public address system and for two-way voice communication.
11. **H/L** - Press briefly to change the transmit power to either High (25 watts) or Low (1 watt).
12. **DISTRESS** - Lift the flap and press this key for 5 seconds to send a distress signal in case of emergency.
13. **SQUELCH** - Rotate clockwise to eliminate background noise when a signal is not being received.

Rear Panel Connectors

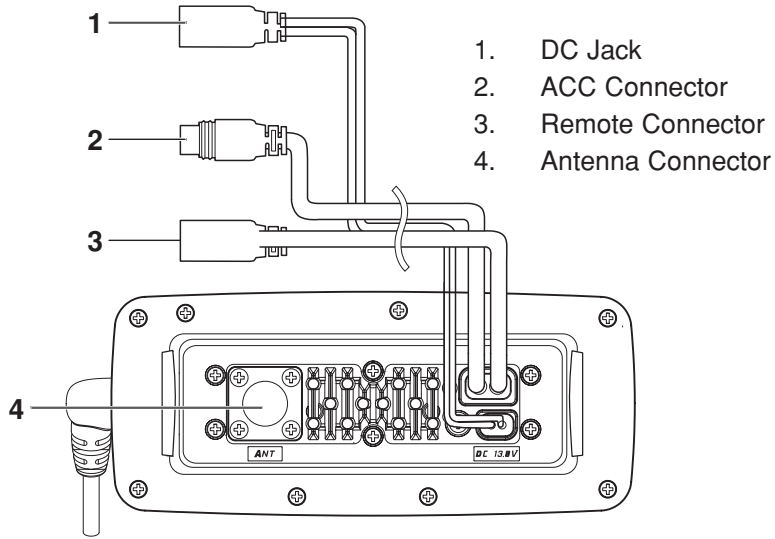

ACC Connector

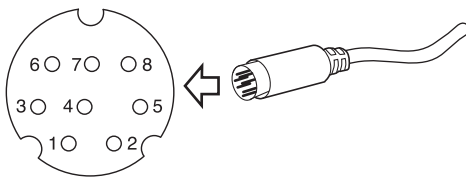

Pin number	Color	Signal
1	ORG	NMEA OUT (-)
2	RED	External Speaker (+)
3	BRN	Hailer (+) Horn Speaker
4	GRN	GPS DATA IN (+)
5	YEL	NMEA OUT (+)
6	BAR	GPS DATA IN (-)
7	BLK	External Speaker (-)
8	BLU	Hailer (-) Horn Speaker

To VHF600

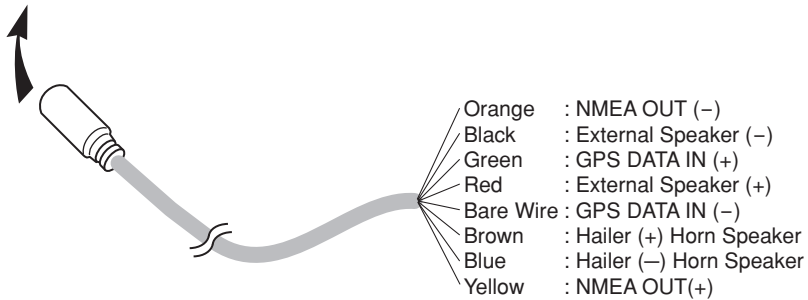

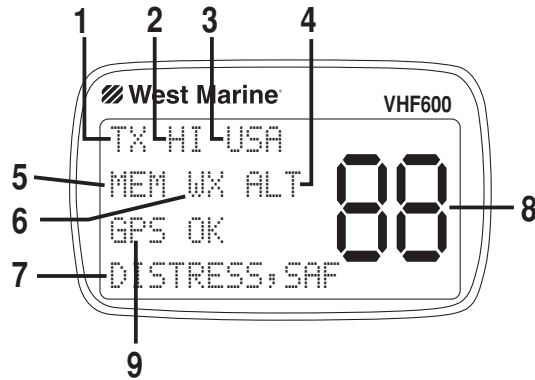

1. **TX** (Transmit) - Indicates the radio is transmitting.
TRI (Triple Watch) - Indicates Triple Watch Mode is in effect.
2. **HI (High)** - Indicates transmit output is 25 watts.
LO (Low) - Indicates transmit output is 1 watt.
3. **USA** - Indicates US Channel Mode.
CAN - Indicates Canadian Channel Mode.
INT - Indicates International Channel Mode.
4. **ALT** - Indicates Weather Alert Mode has been activated.
5. **MEM (Memory)** - Indicates Memory Scan Mode status for each selected channel.
6. **WX** - Indicates Weather Channel Mode has been activated.
7. **CHANNEL NAME** - Shows the currently-tuned channel's name.
8. **Channel Display** - Indicates the current Channel Number.
9. **ALARM SET** - Appears when the alarm is set.
9. **ALARM ACTIVE** - Blinks when the alarm clock is sounding.
9. **GPS OK** - Appears while the **VHF600** is receiving valid GPS data from an external GPS receiver (GPS receiver is optional).
9. **CHECK GPS** - Appears when the GPS data is invalid.
9. **WHAM (Wireless Handheld Access Microphone) OK** - Appears when the **VHF600** is connected to the WHAM's control unit.
9. **BATTERY HIGH** - Appears when the battery voltage is too high. (The Battery High icon appears in this illustration).
9. **BATTERY LOW** - Appears when the battery voltage is too low.

GPS Indicator (External GPS Source Required)

The GPS Indicator screen appears if you connected an optional GPS receiver to the radio and press the **PUSH – SEL** knob.

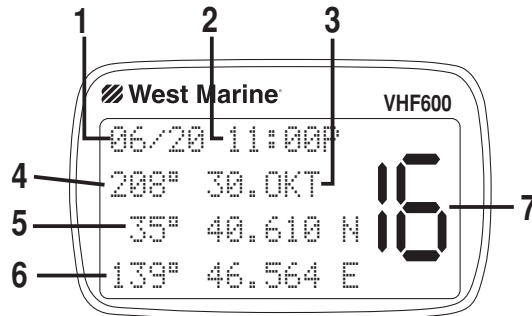

1. **Date** - Shows current date.
2. **Time** - Shows current time.
3. **Speed Data** - Shows current speed.
4. **Angle Data** - Shows current compass direction.
5. **Latitude** - Shows current position information.
6. **Longitude** - Shows current position information.
7. **Channel Display** - Shows the currently-tuned channel.

- Notes:**
- "POS SEND", "TIME ADJUST", "DAYLITE SAVINGS", and "ALARM CLOCK" do not appear on the display if an external GPS receiver is not connected to the radio.
 - When the radio is in one of the following modes: WX Alert mode, Channel 16/9 mode, Scan Mode, or Triple Watch mode and the user presses **MENU**, all of these modes are cancelled.
 - The Menu mode is cancelled if the radio receives a DSC call or any key except + / - or the **PUSH – SEL** knob is pressed.

Installation

Caution: *The VHF600 will only operate with a nominal 13.8 volt negative ground battery system.*

Keep in mind the flexibility designed into the **VHF600** so that you can most conveniently use it. Features which should be considered are:

1. The universal mounting bracket may be installed on either the top or bottom of a shelf, on a bulkhead, or for overhead mounting.
2. The REMOTE speaker wires can be used with an auxiliary speaker.
3. All connections are "plug-in" type for easy removal of the radio.
4. By using an optional WHAM (Wireless Handheld Access Microphone), the **VHF 600** can be mounted completely out of the way.
5. Also optionally available is a flush mount bracket (White - FMB600).

Choosing a Location

Some important factors to consider in selecting the location for your **VHF600**.

1. The **VHF600** is completely waterproof, but will last longer if protected from spray and splash.
2. Keep the battery leads as short as possible. Direct connection to the battery is most desirable. If direct connection can not be made with the supplied power lead, any extension should be made with #12-14 AWG wire. Long extensions should use larger gauge wire.
3. Keep the antenna lead-in wire as short as possible. If you must use a long lead-in wire as in the case of a sailboat masthead antenna installation, we recommend you upgrade your lead-in wire according to the following table:
RG-58 <20'
RG-8X <35'
RG-8U <60'
4. Locate your antenna as high as possible and clear from metal objects. The reliable range of coverage is a direct function of the antenna height.
5. Select a location that allows free air flow around the heat sink on the rear of the radio.
6. Select a location well away from the ship's compass. Auxiliary speakers also should be located away from the compass.

Engine Noise Suppression

Interference from the noise generated by the electrical systems of engines is sometimes a problem with radios. The **VHF600** has been designed to be essentially impervious to ignition noise and alternator noise. However, in some installations it may be necessary to take measures to further reduce the effect of noise interference. The **VHF600** radio DC battery wires, antenna lead, and accessory cables should be routed away from the engine and engine compartment, and from power cabling carrying high currents.

In severe cases of noise interference, it may be necessary to install a noise suppression kit. Contact your West Marine store or dealer where you purchased the radio for more information.

Antenna Considerations

A variety of antennas are available from a number of quality suppliers. In general, we recommend 8' 6dB rated antennas for powerboats, and 4' 3dB antennas for sailboats.

In general, communication range is increased by using a high-gain antenna placed as high as possible above the water line. Antennas should be located away from metal objects. Keep coax feed cables as short as practical.

Antenna Selection and Installation

Your **VHF600** has been designed to accommodate all of the popular marine VHF antennas. However, the selection and the installation of the antenna is the responsibility of the user or installer.

The FCC has determined that excessive radiation poses a health risk to people near radio transmitting antennas. Therefore, the antenna used with this radio should be installed using the following guidelines to ensure a suitable distance between the antenna and persons close by.

- Small whip antennas (3 dB) or smaller should be installed keeping at least 3 feet separation distance between the radiating element and people.
- Larger antennas (6 dB or 9 dB) should be installed keeping at least a 6 feet separation distance.
- No person should touch the antenna or come closer than the separation distance when the radio is transmitting.

Installing the VHF600

After you have carefully considered the various factors affecting your choice of location, position the radio (with the bracket, microphone, power cord, antenna and any auxiliary cables installed) into the selected location to assure there is no interference with the surrounding items. Mark the location of the mounting bracket. Remove the bracket from the radio and use it as a template to mark the holes to be drilled for the mounting hardware. Drill the holes and mount the bracket with hardware compatible with the material of the mounting surface.

Note: *This HEXAGON HEAD BOLT is only for mounting the bracket with hardware. Do not use it for installing the radio in the mounting bracket.*

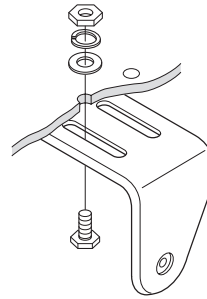

Connect the red wire of the supplied power cord to the positive (+) side of your distribution circuit or battery. Connect the black wire of the supplied power cord to the negative (-) side of your distribution circuit or battery. The power cord is equipped with a fuse to protect the radio. Use only a six (6) amp fast blow fuse for replacement. Connect the power cord to the keyed connector on the power "pigtail".

Connect the antenna and all other auxiliary cables and accessories. Install the radio in the mounting bracket and connect all cables and accessories to the appropriate jacks and connectors.

Note: *Do not use mounting knobs other than the ones supplied. Do not insert the knobs without attaching the bracket.*

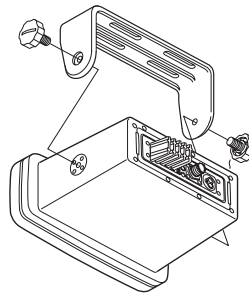

Operation

Power On/Off

Turn on the radio by rotating the **PWR/VOLUME** control clockwise. Then adjust the volume to a comfortable level.

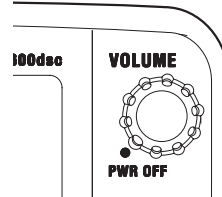

When you turn on the radio, you hear a beep and the greeting message below appears on the display for 2 seconds. Then the main display shown on page 6 appears on the display.

To toggle between the main display and the GPS Indicator screen (if you install an optional GPS receiver), repeatedly press the **PUSH – SEL** knob.

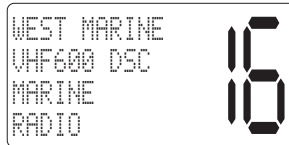

Last Channel Memory

The **VHF600** memorizes the last channel selected before you turn it off. For example, if the **VHF600** is tuned to Channel 16 when you turn it off, it tunes that channel when you turn it back on.

Note: You must tune a channel for at least 3 seconds before the radio will memorize that channel.

Squelch

Turn **SQUELCH** fully clockwise. This raises the “Squelch Gate” so high that only very strong signals can get through.

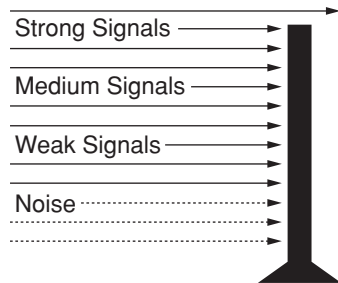
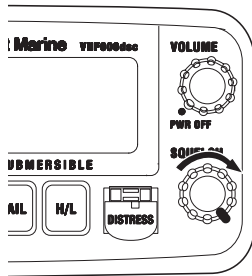

Turn **SQUELCH** fully counterclockwise until you hear a hiss. This lowers the “Squelch Gate” so that everything gets through - noise, weak signals, and strong signals.

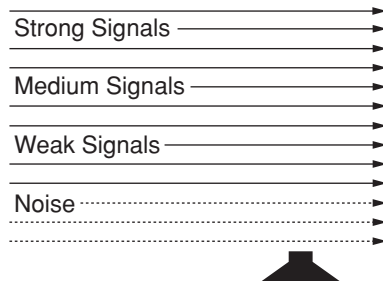
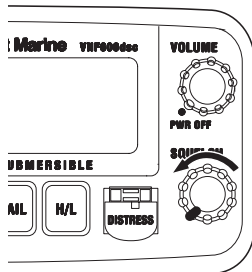

Turn **SQUELCH** back clockwise until the hiss stops. Now the “Squelch Gate” allows only strong signals to get through.

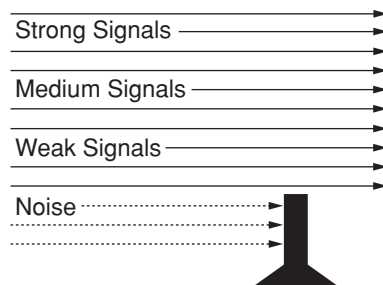
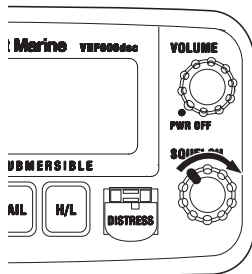

Instant Channel 16/Channel 9 Communications

The radio tunes to Channel 16 (Hailing and Distress) the first time you press the **16/9/TRI** key, even if it is tuned to another channel. The radio tunes to Channel 9 (Hailing and Distress) the second time you press the **16/9/TRI** key. Press **16/9/TRI** a third time to return to the original channel you tuned before you pressed **16/9/TRI**. The selected channel appears on the display.

To cancel Hailing and Distress Channel 16/Channel 9 communications:

- Repeatedly press **16/9/TRI** until the previous channel setting appears.
- or--
- Briefly press **WX/ALERT**, **+ / -** on the microphone, or **SCAN/MEM**.

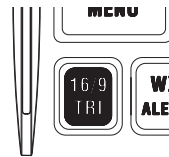

MARINE DISTRESS PROCEDURE

Speak slowly – clearly – calmly.

1. Make sure the radio is on.
2. Tune to Channel 16.
3. Press the PTT button on the microphone then say: "MAYDAY – MAYDAY – MAYDAY."
4. Give your vessel's ID.
5. Say "MAYDAY [your vessel's name]."
6. Give your location (including any nearby navigational aids or landmarks).
7. State the nature of your distress.
8. Give the number of persons aboard and the conditions of any injured.
9. Estimate present seaworthiness of your vessel.
10. Give a brief description of your vessel (meters, type, color, hull).
11. Say: "I will be listening on Channel 16".
12. End message by saying "THIS IS [your vessel's name or call sign] OVER."
13. Release the PTT button and listen. Someone should answer. If not, repeat the call, starting at Item 3 above.

Triple Watch

Triple Watch lets you monitor Channel 16, Channel 9, and the current Marine Channel (home or normal channel) or Weather Channel.

To activate Triple Watch, press and hold **16/9/TRI** for 2 seconds. **TRI** appears on the LCD, indicating Triple Watch mode is in effect. If a signal is received on Channel 9 the radio keeps watching channel 16.

Press and hold **16/9/TRI** for 2 seconds to cancel the Triple Watch mode.

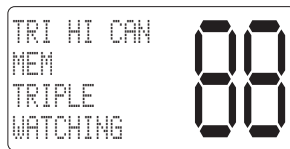

Note: While in Triple Watch mode, you can change the currently selected channel using the **PUSH – SEL** knob. A momentary press of the **16/9/TRI** button interrupts Triple Watch mode and remains on channel 16, or on channel 9 if you press **16/9/TRI** once more. To return to the Triple Watch mode, simply press the button briefly again.

Manually Selecting a Channel

To manually select a channel, rotate the **PUSH – SEL** knob clockwise to increase the number or counterclockwise to decrease it. You can also repeatedly press **+** or **-** on the microphone to change it.

Communication channels are located on channel 01-28 and 60-88.

Weather channels are located on channels 0-9.

Note: In the US, the Coast Guard may refer to Channels 21, 22, 23 etc. as 21 alpha, 22 alpha, etc. The **VHF600** shows these channels in the USA mode as channel 21, 22, 23, etc.

Weather Channels

To select Weather Channels 0-9, press **WX/ALERT** briefly. The radio will tune to the last selected Weather Channel. Press **+** or **-** on the microphone to select a different Weather Channel. It also can be changed by the **PUSH - SEL** knob on the base.

To exit the Weather Channel, press **WX/ALERT** briefly. The radio returns to the previous Marine channel.

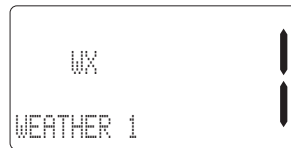
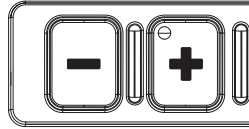

Entering Channel Numbers into Memory Scan

You can enter channels into the radio's memory so they can be rapidly scanned. This means that you can have the radio move from one memorized channel to the next, and have it stop to monitor the channel only if there is traffic or conversations on that channel.

To enter a channel into Memory Scan, select the channel you want to store by rotating the **PUSH - SEL** knob, then press and hold **SCAN/MEM** for 2 seconds. The channel is stored in Memory Scan and MEM appears on the LCD display.

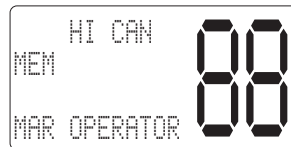

To cancel the channel in memory, press and hold **SCAN/MEM** for 2 seconds. The **MEM** icon disappears.

Note: *The Memory channel can be set independently in 3 regional modes (USA, INT, and CAN). You cannot use this feature in WX mode or for channel 70.*

Memory Channel Scan

This feature will allow you to scan only the channels of your choice.

Memory Channel Scan can only be activated if channels have previously been placed into memory.

To turn on Memory Channel Scan, press **SCAN/MEM**. The **VHF600** scans the channels that were previously placed into memory, from the lowest channel number to the highest channel number.

Triple Watch Alert Scan

This feature will allow you to listen to the channel of your choice. scan channels 16 and 9 every 2 seconds, and scan for Emergency or Weather Alerts every 7 seconds to be sure that you will not miss any important broadcasts.

To turn Triple Watch Alert Scan on, press and hold **WX/ALERT** for 2 seconds while in Memory Channel Scan mode. While the Memory Channels are scanned, Channel 16 and Channel 9 are scanned every 2 seconds, and the Weather Channel is scanned every 7 seconds. "TRI" and "ALT" appear on the display.

Alert Scan

This feature will allow you to scan the channels of your choice and also scan the Weather channels for Emergency or Weather alerts.

To turn Alert Scan On, press and hold **WX/ALERT** for 2 seconds. While the memory channels are scanned, the Weather Channel is scanned every 7 seconds. The icon appears on the display.

Hail

To access the Hail mode, press **HAIL** on the base. HA appears on the display. Press and hold the PTT switch on the microphone, hold the microphone approximately two inches away from your mouth, and speak clearly in a normal voice. To cancel Hail mode, press **HAIL** on the base again.

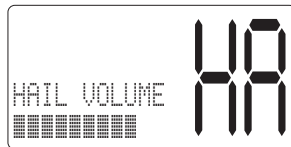

Adjusting the Hail Volume

While you are in Hail mode, you can adjust the outgoing volume by pressing **+/-** on the microphone, or by rotating the **PUSH – SEL** knob on the **VHF600**. The incoming volume is adjusted by using the **PWR/VOLUME** knob.

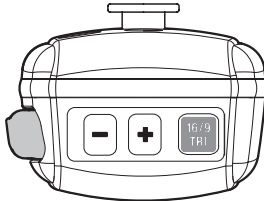

Note: *If you purchase an optional hailer horn for the radio, make sure it meets these specifications.*

- 17 Watts (nominal)
 - 10 Watts (minimum)
 - 4 Ω load (impedance)
- * RE-ENTRANT feature might not work on all models.

Weather Alert

Traditional weather radios receive weather broadcasts (usually within a 50-mile radius) then sound an alarm when any emergency code is transmitted along with the broadcast. This means that people who live outside an affected area are often alerted even when their area is not affected, causing many of them to ignore potentially real emergency/weather warnings that can save lives.

Your radio's Weather Alert feature lets it monitor the local weather channel for NOAA weather alert broadcasts, while allowing you to listen to other channels.

About S.A.M.E. Weather Alert

In 1994, the National Oceanic and Atmospheric Administration (NOAA) began broadcasting coded signals called FIPS (Federal Information Processing System) codes along with their standard weather broadcasts from stations in your area. These codes identify an emergency and the specific geographic area (such as a county) affected by the emergency.

Your radio's SAME (Specific Area Message Encoding) technology lets it receive, interpret, and display information about the codes it receives so you can determine if an emergency might affect your area.

Each FIPS code identifies a specific geographic area (defined by the National Weather Service), so your radio sounds an alert only when an emergency/weather emergency is declared in those locations. This helps you more efficiently track the emergency/weather conditions in and around your area.

When the **VHF600** receives a weather alert:

- It sounds an alert siren.
- A description of the alert appears.

The alert descriptions your radio can display are based on a list of specific weather alert types published by the NWS (National Weather Service). For a list of all the alert descriptions that your radio can display, see "NWR-SAME Event Codes" on page 70.

Caution: The NWS uses sophisticated weather models to determine an alert's effective time. However, the end of an alert does not necessarily mean that the related weather emergency is over.

The radio's Weather Alert mode can alert you when dangerous weather is in your area. When Weather Alert is turned on and a warning signal is received, an emergency siren sounds at full volume, regardless of the volume setting. When the signal stops, you hear the active weather channel broadcast at its normal volume.

Note: See "Selecting a FIPS Code" on page 44 for more information about working with FIPS codes.

The ALT icon indicates the Weather Alert mode is active. To activate the Weather Alert mode:

1. Press **WX/ALERT** for more than 2 seconds when WX/ALERT is off. The radio turns WX/ALERT on and the ALT icon appears.

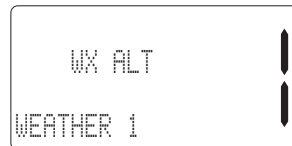

2. If the radio receives a 1050Hz tone, the ALT icon blinks every other second.

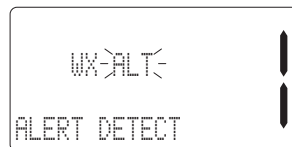

3. When a WX/ALERT signal is received, all other functions are canceled and the radio remains on the selected weather channel.

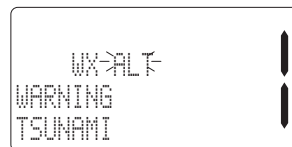

Important: The radio does not decode a SAME signal when it is in Scan mode. To decode the SAME signal, set the radio to an active weather channel.

To stop the alert, briefly press any key. If you press any key again, the alert icon disappears.

Note: The radio must be tuned to an active weather channel to decode the SAME signal. This is because the SAME signal is only broadcast at the beginning of the 10 second weather alert tone broadcast by the National Weather Service.

Setting Transmit (TX) Power

The **VHF600** transmits on 55 marine frequencies and receives on 80 marine frequencies. Channel 70 of the USA, International, and Canadian frequencies, and channel 15, of the USA frequencies, and WX CH – are for receiving only. The **VHF600** transmits on channel 70 when sending DSC information. Your radio will not transmit on these channels. For your reference, a listing of all the available marine channels is located on pages 67 - 69.

Setting TX Output

Caution: *Be sure to set the TX output to LO while in port or for short range communications.*

1. When you turn the **VHF600** on for the first time, it is automatically set to transmit at 25 watts (HI).

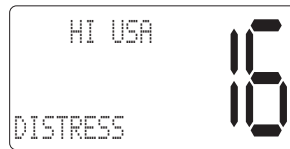

2. Press **H/L** briefly to change the transmitter output to 1 watt (LO).

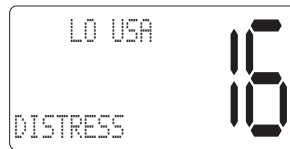

3. Press **H/L** again to change back to 25 watts (HI).

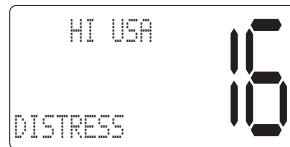

Note: *A short tone sounds every time you press **H/L**. CH13 is a 1 watt (LO) channel. When the channel is a LO power channel, you can transmit at 25 watts (HI) by pressing **H/L** during the call. LO power channels are USA Channels 13, 17, 67, 77; Canadian Channels 13,15,17,20,66,77, and INT Channels 15,17. Use low transmit power in harbors or when close to the receiving station. You cannot change the transmit power setting on channels which are receive-only channels, including all weather channels, USA Channels 15, 70, Canadian Channel 70, and International Channel 70.*

Sending a Distress Call

Important: You must set a user MMSI before you can send a Distress call. Please see page 60 to set the MMSI.

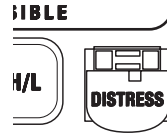

This feature lets you transmit a Distress call.

1. To transmit a Distress call, flip up the button cover then press and hold **DISTRESS** for 5 seconds. The following screen appears.
2. Select **SEND** to confirm the Distress call or **CANCEL** to cancel it. If you select **CANCEL**, the display returns to the channel display screen.
3. Press the **PUSH – SEL** knob to send the Distress call. The radio transmits the Distress call then waits for an acknowledgement signal for about 210 - 270 seconds. After the Distress call has been sent, the Distress alert sounds every other second. The radio also "shadow-watches" for a transmission between CH16 and CH70 until an acknowledgement signal is received from the Coast Guard shore station.
4. To cancel the Distress call, press the **PUSH – SEL** knob.
5. When the **VHF600** receives a Distress call, the following screen appears. The Distress call is repeated until an acknowledgement is received from the Coast Guard shore station.

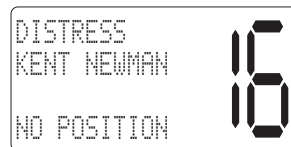
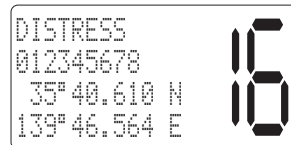
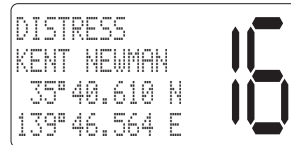
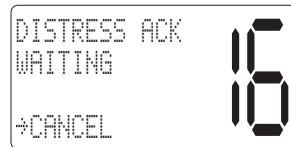
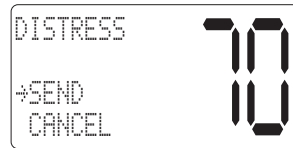

Note: If the **VHF600** receives a Distress call, it appears on the display and the radio sounds an emergency alert. The name of the vessel that sent the Distress call is displayed if it is a name registered in the directory. Otherwise, the vessel's MMSI is displayed. Latitude, longitude, and time information also appear if a GPS receiver is installed in the vessel that sent the Distress call.

Using the Menu

Menu Flow Chart

Your radio's menu functions are structured in the following order.

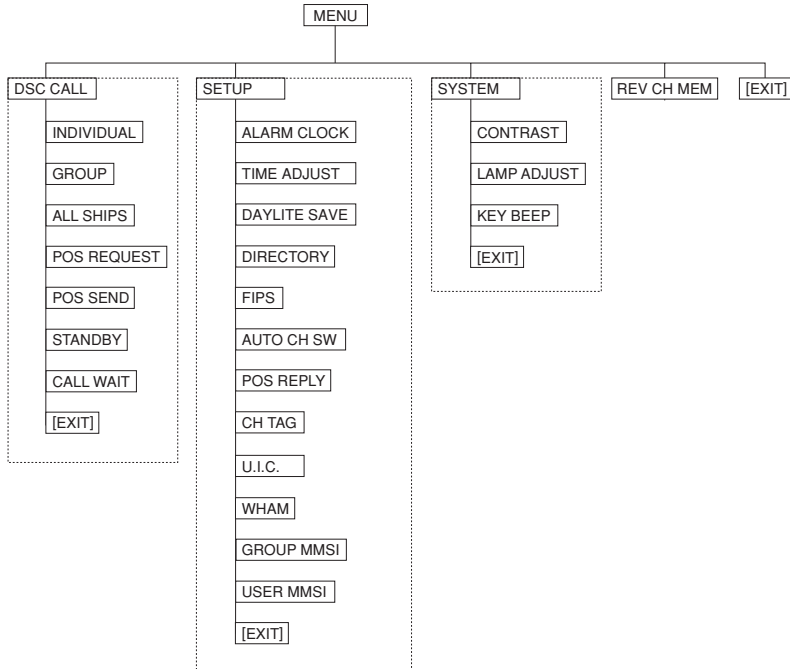

Selecting Items From The Menu

1. Press **MENU** briefly.
2. Press the **PUSH – SEL** knob at DSC CALL, SETUP, SYSTEM, or REV CH MEM.



Using Digital Selective Calling (DSC)

Digital Selective Calling (DSC) is a protocol that has been chosen by the International Maritime Organization (IMO) as an international standard for establishing VHF, MF and HF radio calls. DSC has also been selected to be part of the Global Maritime Distress and Safety System (GMDSS).

DSC lets you instantly send a Distress call with GPS position (when you connect an optional GPS receiver to the **VHF600**) to the US Coast Guard and other vessels within range of the transmission.

DSC also lets you initiate or receive distress, urgency, safety, position information and routine calls to or from another vessel outfitted with a DSC transceiver.

The **VHF600** includes the following DSC features:

INDIVIDUAL CALL - Quickly call other vessels from your calling directory.

GROUP CALL - Easily call a group of vessels.

ALL SHIPS CALL - Allows you to send Urgent, Safety-related, or Routine calls to all vessels in your area.

POSITION REQUEST - Easily request the position of a vessel in your call directory.

POSITION SEND - Send your position information to a vessel in your call directory.

STANDBY - Lets you acknowledge calls with "Unavailable" while you are away from your vessel.

CALL WAITING - Your **VHF600** will automatically log incoming calls into a directory so you can receive them later if you are not available to take the call immediately.

See the directory section for instructions on how to set up the directory of names.

Note: *You must connect an optional GPS receiver to the radio to use the position send, alarm clock, and adjusting the time features described in this section.*

Individual

This feature lets you contact another vessel and automatically switch the receiving DSC radio to the desired channel.

1. Select an open channel.
2. Press **MENU** briefly.
3. Press the **PUSH – SEL** knob to select **DSC CALL**. The DSC CALL menu appears.
4. Press the **PUSH – SEL** knob. The individual directory appears.
5. Rotate the **PUSH – SEL** knob to select the individual you want to contact, then press the **PUSH – SEL** knob.
6. Press the **PUSH – SEL** knob to transmit the individual DSC signal.
7. When you receive an individual acknowledgement, the following screen appears, and both radios tune to the previously selected channel. You are now ready to transmit on that channel.
or
 When the called radio has been set to standby mode, the following screen appears.

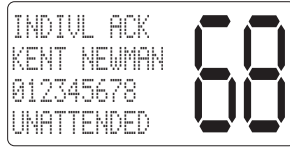
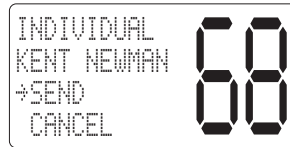
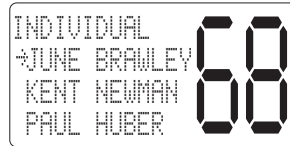
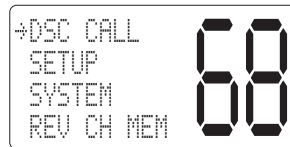

- Notes:**
- If there is no data registered in the directory, you cannot do step 4 in this procedure. See "Setting Up the Directory" on page 38 for directory setup instructions.
 - Select an open (unused) working channel first, then make the call. After the acknowledgement, both radios tune to the previously selected channel.

Group

This function lets you contact a group of specific vessels using DSC and automatically switch to a desired channel. This function also lets you transmit a DSC signal with a group MMSI.

1. Select an open channel.
2. Press **MENU** briefly.
3. Press the **PUSH – SEL** knob to select **DSC CALL**. The DSC CALL menu appears.
4. Rotate the **PUSH – SEL** knob to select **GROUP**.
5. Press the **PUSH – SEL** knob. The MMSI code appears and you can now call the group members. Press the **PUSH – SEL** knob at **SEND** and the **VHF600** returns to the channel display screen.

HI CAN
NON COMMERCL
68

→DSC CALL
SETUP
SYSTEM
REV CH MEM
68

INDIVIDUAL
→GROUP
ALL SHIPS
POS REQUEST
68

GROUP
100000001
SEND
→CANCEL
68

HI CAN
NON COMMERCL
68

All Ships Call

This function lets you send any of the following types of ALL SHIPS calls:

- **Urgency** - This call is for a vessel not yet in Distress, but may have a serious problem.
- **Safety** - This call is used for a reason like debris in the water.
- **Routine** - This call is used for normal calls.

1. Press **MENU** briefly.

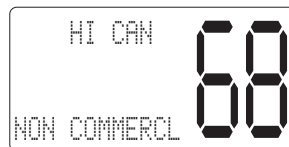

2. Press the **PUSH – SEL** knob to select **DSC CALL**. The DSC CALL menu appears.



3. Rotate the **PUSH – SEL** knob to select **ALL SHIPS**.

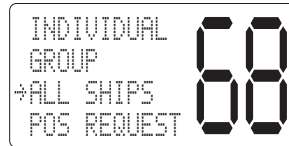

4. Press the **PUSH – SEL** knob. The ALL SHIPS directory appears.

5. Rotate the **PUSH – SEL** knob to select the nature of your call (URGENCY, SAFETY, ROUTINE).

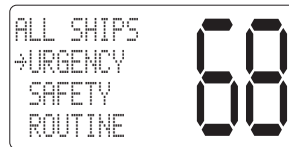

Note: ROUTINE calls tune to the previously selected channel.

6. Press the **PUSH – SEL** knob to transmit the ALL SHIPS DSC signal.

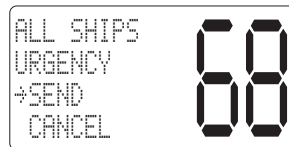

- When sending either an **URGENCY** or **SAFETY** message, all radios automatically tune to channel 70 until all of the data is received.

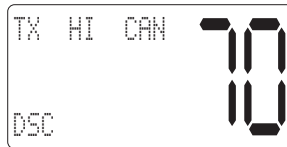

- The radio automatically tunes to Channel 16 after it transmits an **URGENCY** or **SAFETY ALL SHIPS** call. You should wait a few minutes before transmitting ALL SHIPS call information.

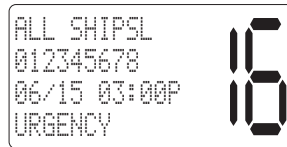

Position Request

This function lets you request the position of an individual vessel registered in the Directory.

Note: *The radio for which you want to receive position data must transmit the data before you can receive it. VHF600 radios can transmit and receive position data.*

- Press **MENU** briefly.
- Press the **PUSH – SEL** knob to select **DSC CALL**. The **DSC CALL** menu appears.
- Rotate the **PUSH – SEL** knob to select **POS. REQUEST**.
- Press the **PUSH – SEL** knob. The individual directory appears.
- Rotate the **PUSH – SEL** knob to select the vessel's name.

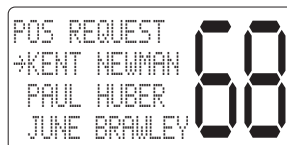
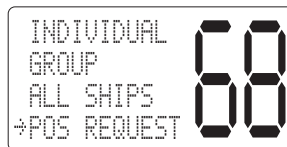
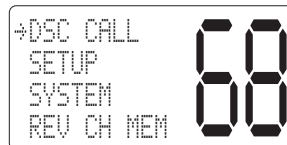

6. Press the **PUSH – SEL** knob. The following screen appears. Confirm if the name and address are correct. Then press the **PUSH – SEL** knob to select **SEND**.

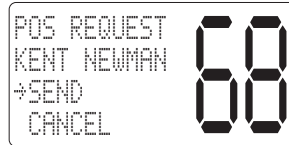

7. If the **VHF600** does not receive an acknowledgement, the following screen appears.

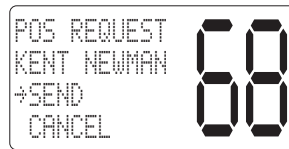

8. When the called vessel sends its position information, the following screen appears.

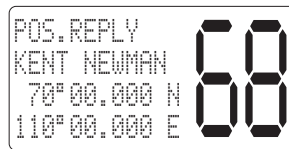

Position Send

This function lets you send your vessel's position to another vessel using a VHF marine radio equipped with DSC.

Note: You must connect an optional GPS receiver to your radio to use position send.

1. Press **MENU** briefly.
2. Press the **PUSH – SEL** knob to select **DSC CALL**. The **DSC CALL** menu appears.

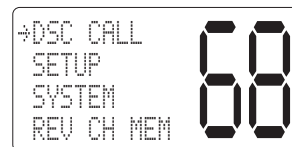

3. Rotate the **PUSH – SEL** knob to select POS. SEND.

```

GROUP
ALL SHIPS
POS REQUEST
->POS SEND
68
    
```

4. Press the **PUSH – SEL** knob. The individual directory appears.
5. Rotate the **PUSH – SEL** knob to select the name where you want to send your position information.

```

POS SEND
->KENT NEWMAN
PAUL HUBER
JUNE BRAWLEY
68
    
```

6. Press the **PUSH – SEL** knob. The following screen appears. Confirm if the name and address are correct. Then press the **PUSH – SEL** knob to select SEND.

```

POS SEND
KENT NEWMAN
->SEND
CANCEL
68
    
```

7. When the calling radio receives an acknowledgement, the following screen appears.

```

POS SEND
KENT NEWMAN
70°00.000 N
110°00.000 E
68
    
```

Standby

The DSC STANDBY function lets the **VHF600** answer DSC calls with the UNATTENDED message and record calls for response at another time. When you set the **VHF600** to DSC STANDBY mode, voice traffic may still be active on any chosen channel.

1. Press **MENU** briefly.

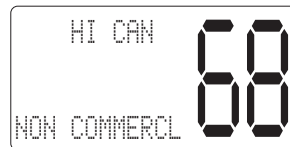

2. Press the **PUSH – SEL** knob to select **DSC CALL**. The DSC CALL menu appears.



3. Rotate the **PUSH – SEL** knob at **STANDBY**.

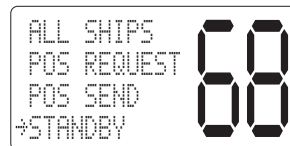

4. Press the **PUSH – SEL** knob. The **STANDBY** directory appears.

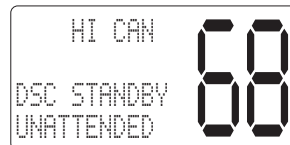

5. When an individual DSC call is received, the radio responds with the UNATTENDED message when an operator cannot answer the call. Then the radio records the DSC call into its Call Waiting directory.

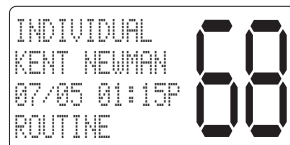

Note: Standby is canceled when you press a key on the radio or the mic.

Call Wait

The DSC Call Waiting function records up to 10 received distress calls, and records up to 20 individual calls that are received and not answered within 5 minutes or while the radio is set to DSC Standby. The radio records these calls while you are busy with other communications as long as the transmitter is not keyed at the time of the call. If the call is answered within 5 minutes, the call is not recorded. When a call is recorded, a message appears.

1. Press **MENU** briefly.



2. Press the **PUSH – SEL** knob to select **DSC CALL**. The **DSC CALL** menu appears.



3. Rotate the **PUSH – SEL** knob to select **CALL WAIT**.

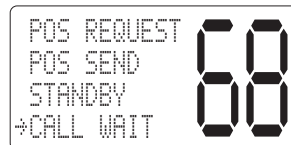

4. Press the **PUSH – SEL** knob. The **CALL WAIT** directory appears.
5. Rotate the **PUSH – SEL** knob to select the options you want to view.

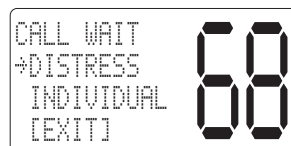

Note: At least one call must be logged before you can proceed to the next step. If a call has not been logged, the **VHF600** beeps and you cannot proceed.

6. Press the **PUSH – SEL** knob.
7. Rotate the **PUSH – SEL** knob to select the information.

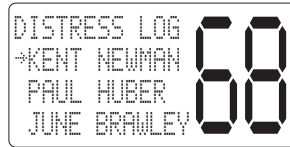

8. Press the **PUSH – SEL** knob to get further information about the call received.
If a DISTRESS call is received in Call Wait, the following display appears.

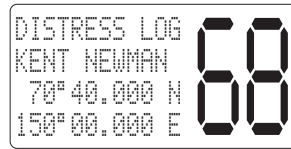

If an INDIVIDUAL call is received in Call Wait, the following display appears. At this point, you can call back any of the radios in the log.

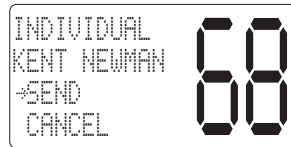

Using Setup

1. Press **MENU** briefly.
2. Press the **PUSH – SEL** knob at **SETUP**.

SETUP has 12 options as follows. To exit, select **EXIT**.

Alarm Clock

The alarm clock function works only if a GPS receiver is connected to the radio. The GPS receiver provides the time data for the alarm clock. You must set the time before you set the alarm clock. See “Adjusting the Time” on page 36 for more information.

Setting the Alarm

This feature allows you to set the alarm.

1. Press **MENU** briefly.
2. Press the **PUSH – SEL** knob at **SETUP**. The **SETUP** menu appears.
3. Rotate the **PUSH – SEL** knob to select **ALARM CLOCK**.
4. Press the **PUSH – SEL** knob.
5. Press the **PUSH – SEL** knob at **ALARM SET**.

HI CAN
NON COMMERCL 68

DSC CALL
→SETUP
SYSTEM
REV CH MEM 68

→ALARM CLOCK
TIME ADJUST
DAYLITE SAV
DIRECTORY 68

ALARM CLOCK
→ON
OFF
ALARM SET 68

6. You can set the hour, the minute, and AM or PM by rotating the **PUSH – SEL** knob. It will be entered when the **PUSH – SEL** knob is pressed, and the blinking digit moves to the right.

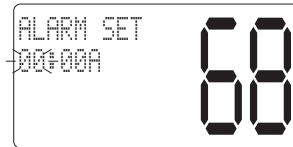

7. Press the **PUSH – SEL** knob after you select AM or PM. A confirmation screen appears. Press the **PUSH – SEL** knob and the **VHF600** returns to the ALARM CLOCK menu.

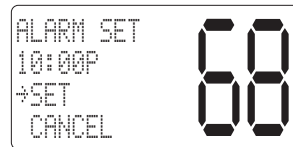

Turning the Alarm On

This feature allows you to turn on the alarm.

1. Press **MENU** briefly.
2. Press the **PUSH – SEL** knob at **SETUP**. The **SETUP** menu appears.
3. Rotate the **PUSH – SEL** knob to select **ALARM CLOCK**.
4. Press the **PUSH – SEL** knob.
5. Press the **PUSH – SEL** knob to select **ON**. The **VHF600** returns to the channel display screen and **ALARM SET** appears.

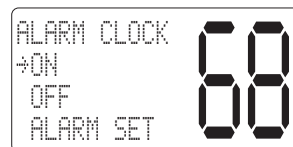
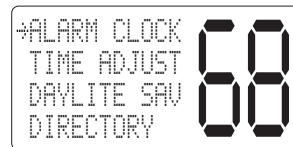
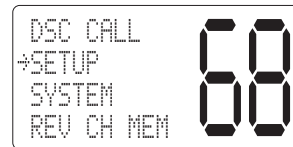

- When the **VHF600** reaches the set time the alarm sounds and **ALARM ACTIVE** and time display blinks.



Note: The alarm sounds when the set time is reached. You can turn off the alarm by pressing any key. Alarm mode turns off automatically when the alarm sounds.

Turning the Alarm Off

This feature allows you to turn off the alarm.

- Press **MENU** briefly.
- Press the **PUSH – SEL** knob at **SETUP**. The **SETUP** menu appears.
- Rotate the **PUSH – SEL** knob to select **ALARM CLOCK**.
- Press the **PUSH – SEL** knob.
- Press the **PUSH – SEL** knob at **OFF**. The **VHF600** returns to the channel display screen and **ALARM SET** disappears.

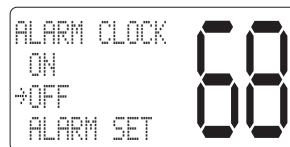
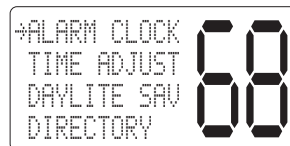
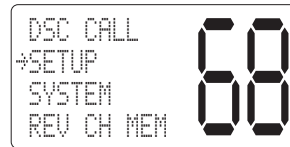

Adjusting the Time

This feature allows you to set the time difference between local time and the time that GPS receiver provided. This feature is available only when a GPS receiver is connected to the radio.

1. Press **MENU** briefly.

```

06/15 11:00P
054° 30.0KT
70°00.000 N
100°00.000 W
68

```

2. Press the **PUSH – SEL** knob at **SETUP**. The **SETUP** menu appears.

```

DSC CALL
→SETUP
SYSTEM
REV CH MEM
68

```

3. Press the **PUSH – SEL** knob at **TIME ADJUST**.

```

ALARM CLOCK
→TIME ADJUST
DAYLITE SAV
DIRECTORY
68

```

4. Rotate the **PUSH - SEL** knob to select the appropriate time (auto adjusted time).

```

TIME ADJUST
00:23A
68

```

5. Press the **PUSH - SEL** knob.

```

TIME ADJUST
01:23A
68

```

6. A confirmation screen appears. To confirm the time you entered, select **SET**. Otherwise, select **CANCEL**. Then press the **PUSH - SEL** knob.

```

TIME ADJUST
01:23A
→SET
CANCEL
68

```

Setting Daylight Saving Time

This feature allows you to set up the time difference automatically by using an optional GPS receiver.

1. Press **MENU** briefly.

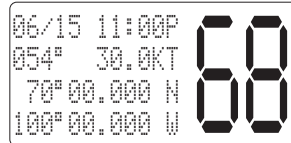

2. Press the **PUSH - SEL** knob at SETUP. The SETUP menu appears.



3. Press the **PUSH - SEL** knob at DAYLITE SAV.



4. Press the **PUSH - SEL** knob to select ON. The SETUP menu appears.



Setting Up the Directory

This function lets you send an individual call, etc. The Directory function lets you store the name and number of up to 20 other vessels. You can set up your vessel's alphanumeric identity and MMSI number in the directory.

Follow these steps to use the Directory menu.

1. Press **MENU** briefly.



2. Press the **PUSH – SEL** knob at **SETUP**. The **SETUP** menu appears.



3. Press the **PUSH – SEL** knob at **DIRECTORY**. The **DIRECTORY** menu appears.

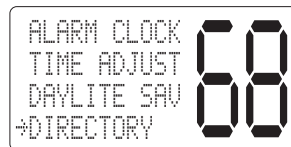

Entering New Information

1. Press **MENU** briefly.

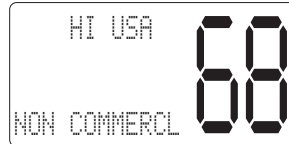

2. Press the **PUSH – SEL** knob at **SETUP**. The **SETUP** menu appears.



3. Press the **PUSH – SEL** knob at **DIRECTORY**. The **DIRECTORY** menu appears.

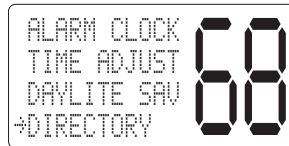

4. Press the **PUSH – SEL** to select **NEW**.

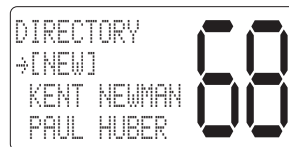

5. You can now enter the person's name. Rotate and press the **PUSH – SEL** knob to select a letter. The character will be entered when you press the **PUSH – SEL** knob. Press **PUSH – SEL** knob for more than two seconds when you enter the last character.

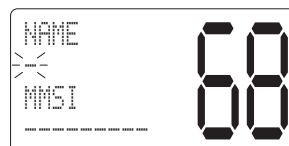

6. After you enter the person's name, you can enter their MMSI number. Rotate the **PUSH – SEL** knob clockwise to increase the number, or counterclockwise to decrease it. The number will be entered when you press the **PUSH – SEL** knob. The blinking digit moves to the right.

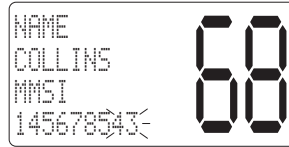

After the directory data is entered, a confirmation screen appears.

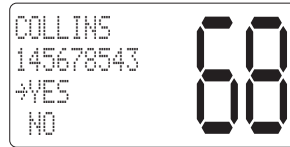

To confirm the name you entered, select YES. Otherwise, select NO. Then press the **PUSH – SEL** knob. The **VHF600** returns to the following screen.

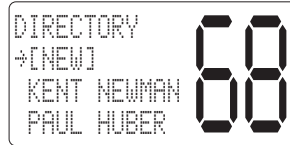

Editing Existing Information

1. Press **MENU** briefly.
2. Press the **PUSH – SEL** knob at **SETUP**. The **SETUP** menu appears.
3. Press the **PUSH – SEL** knob at **DIRECTORY**. The **DIRECTORY** menu appears.
4. Press the **PUSH – SEL** knob at the name you want to edit.
5. Press the **PUSH – SEL** knob to select **EDIT**.

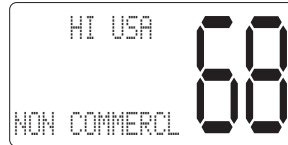

HI USA
NON COMMERCIAL
68.00



DSC CALL
→SETUP
SYSTEM
REV CH MEM
68.00

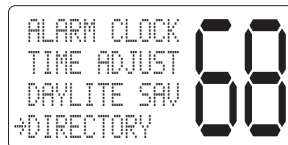

ALARM CLOCK
TIME ADJUST
DAYLITE SAV
→DIRECTORY
68.00

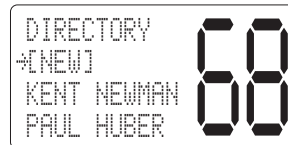

DIRECTORY
→[NEW]
KENT NEWMAN
PAUL HUBER
68.00

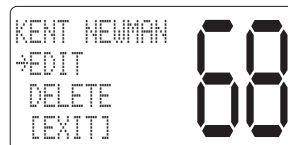

KENT NEWMAN
→EDIT
DELETE
[EXIT]
68.00

6. You can now edit the person's name. Rotate then press the **PUSH – SEL** knob to select a character. The character will be entered when you press the **PUSH – SEL** knob. Press **PUSH – SEL** knob for more than two seconds when you enter the last character

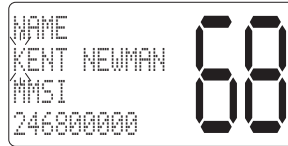

7. After you edit the person's name, you can edit the MMSI. Rotate the **PUSH – SEL** knob clockwise to increase the number, or counterclockwise to decrease it. The number will be entered when you press the **PUSH – SEL** knob. The blinking digit moves to the right.

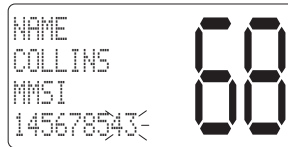

After the directory data is edited, a confirmation screen appears.



Press the **PUSH – SEL** knob. The **VHF600** returns to the following screen.



Deleting Information

1. Press **MENU** briefly.
2. Press the **PUSH – SEL** knob at **SETUP**. The **SETUP** menu appears.
3. Press the **PUSH – SEL** knob at **DIRECTORY**. The **DIRECTORY** menu appears.
4. Press the **PUSH – SEL** knob at the name you want to delete.
5. Press the **PUSH – SEL** knob at **DELETE**.
6. Press the **PUSH – SEL** knob.

```

HI USA      68
NON COMMERCIAL
    
```

```

DSC CALL   68
->SETUP
SYSTEM
REV CH MEM
    
```

```

ALARM CLOCK 68
TIME ADJUST
DAYLITE SAV
->DIRECTORY
    
```

```

DIRECTORY   68
[NEW]
JIM CASSIDY
->KENT NEWMAN
    
```

```

KENT NEWMAN 68
EDIT
->DELETE
[EXIT]
    
```

```

KENT NEWMAN 68
DELETE
->YES
NO
    
```

The **VHF600** returns to the following screen.

```

DIRECTORY   68
[NEW]
->JIM CASSIDY
[EXIT]
    
```

Selecting a FIPS Code

The 6-digit Federal Information Processing System (FIPS) code established by the National Weather Service (NWS) identifies geographic areas in the United States. Programming FIPS codes are necessary to receive SAME alerts about weather occurring in a particular area. To obtain the FIPS code for a particular area contact the NWS toll free at 1-888-NWR-SAME (1-888-697-7263).

Or visit their website: <http://www.nws.noaa.gov/nwr/indexnw.htm>

A list of event codes is located on page 70.

1. Press **MENU** briefly.

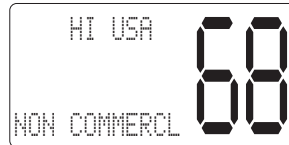

2. Press the **PUSH – SEL** knob at **SETUP**. The **SETUP** menu appears.



3. Press the **PUSH – SEL** knob at **FIPS**.



Registering a New FIPS Code

1. Press **MENU** briefly.
2. Press the **PUSH – SEL** knob at **SETUP**. The **SETUP** menu appears.
3. Press the **PUSH – SEL** knob at **FIPS**.
4. Press the **PUSH – SEL** knob to select **NEW**.
5. You can now enter the new FIPS code. Rotate the **PUSH – SEL** knob clockwise to increase the number, or counterclockwise to decrease it. The number will be entered when the **PUSH – SEL** knob is pressed, and the blinking digit moves to the right. When you finished entering the last digit, the following confirmation screen appears.
6. Press the **PUSH – SEL** knob. The **VHF600** returns to the following screen.

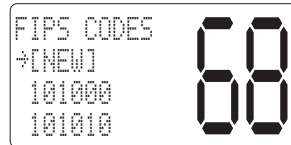
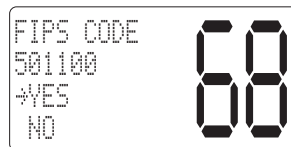
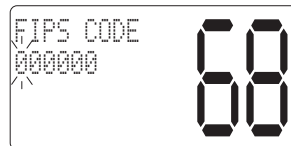
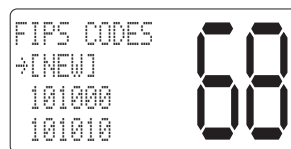
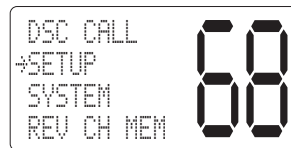
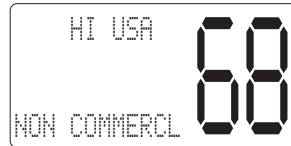

Editing a FIPS Code

1. Press **MENU** briefly.
2. Press the **PUSH – SEL** knob at **SETUP**. The SETUP menu appears.
3. Press the **PUSH – SEL** knob at **FIPS**.
4. Press the **PUSH – SEL** knob at the FIPS code you want to edit.
5. Press the **PUSH – SEL** knob to select **EDIT**.
6. You can now edit the FIPS code. Rotate the **PUSH – SEL** knob clockwise to increase the number, or counterclockwise to decrease it. The number will be entered when you press the **PUSH – SEL** knob. The blinking digit moves to the right.

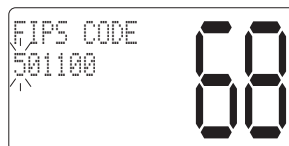
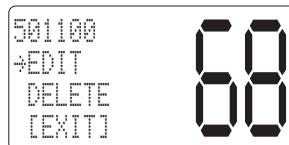
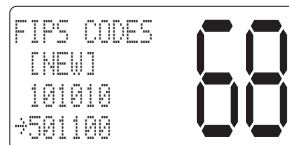
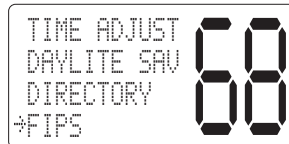
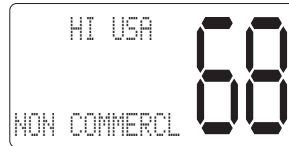

- When you finished editing the last digit, the following confirmation screen appears.

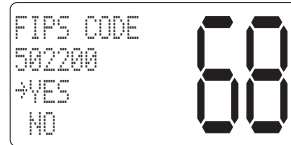

- Press the **PUSH – SEL** knob. The **VHF600** returns to the following screen.

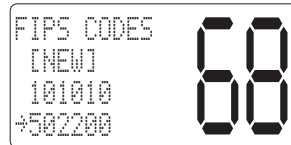

Deleting a FIPS Code

- Press **MENU** briefly.



- Press the **PUSH – SEL** knob at **SETUP**. The **SETUP** menu appears.

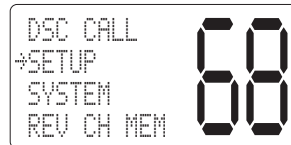

- Press the **PUSH – SEL** knob at **FIPS**.



4. Press the **PUSH – SEL** knob at the code you want to delete.

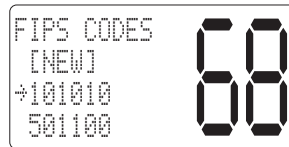

5. Press the **PUSH – SEL** knob at DELETE.

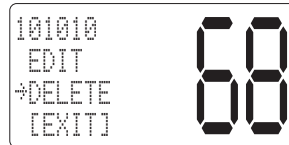

6. Press the **PUSH – SEL** knob. The **VHF600** returns to the following screen.

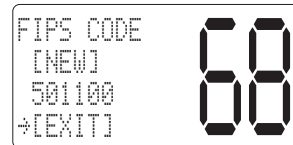

Auto Channel Switch

This feature lets you disable the automatic channel change that occurs when you receive a DSC call. This feature is useful when you are making a bridge-to-bridge or other safety related call. When you complete a call, all incoming DSC calls are available in the call log.

1. Press **MENU** briefly.



2. Press the **PUSH – SEL** knob at **SETUP**. The **SETUP** menu appears.

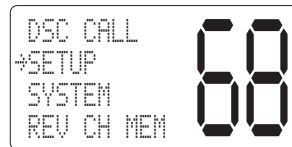

3. Rotate the **PUSH – SEL** knob to select **AUTO CH SW**.

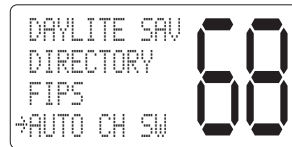

4. Press the **PUSH – SEL** knob. The following screen appears.

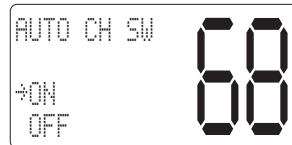

5. To change this mode to **OFF**, rotate the **PUSH – SEL** knob. (Default is set to **ON**.)



6. Press the **PUSH – SEL** knob. The **VHF600** returns to the following screen.

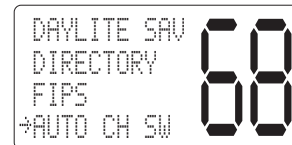

Position Reply

This feature lets you transmit an acknowledgement automatically or on a call-by-call basis when another vessel requests your position information.

1. Press **MENU** briefly.

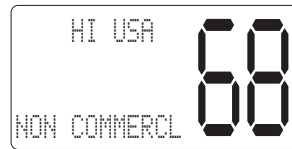

2. Press the **PUSH – SEL** knob at **SETUP**. The **SETUP** menu appears.



3. Rotate the **PUSH – SEL** knob to select **POS REPLY**.

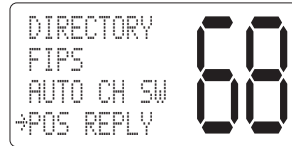

4. Press the **PUSH – SEL** knob. The following screen appears.

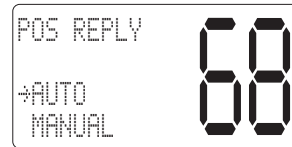

5. Rotate the **PUSH – SEL** knob to select **AUTO** or **MANUAL**.

AUTO

When the **VHF600** receives a position request, the following screen appears.

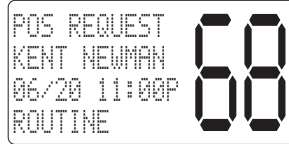

MANUAL

When the **VHF600** receives a position request, the following screen appears. Rotate the **PUSH – SEL** knob to select **REPLY** or **CANCEL**.

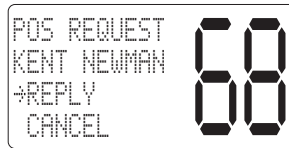

6. Press the **PUSH – SEL** knob. The **VHF600** returns to the following screen.

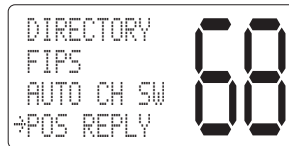

Channel Name (CH Tag)

This feature lets you name each Marine channel.

Note: The **VHF600** radio comes pre-programmed with default channel names. But you can change them.

1. Press **MENU** briefly.
2. Press the **PUSH – SEL** knob at **SETUP**. The **SETUP** menu appears.
3. Rotate the **PUSH – SEL** knob to select **CH TAG**.
4. Press the **PUSH – SEL** knob. The following screen appears.
5. Press the **PUSH – SEL** knob at the channel that you would like to edit or default.

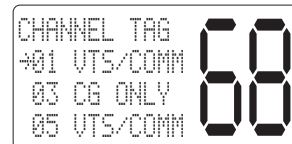
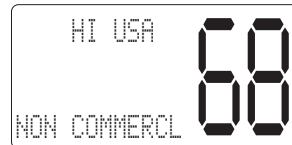

Editing a Channel Name

This feature lets you edit a channel name.

1. Press **MENU** briefly.
2. Press the **PUSH – SEL** knob at **SETUP**. The **SETUP** menu appears.

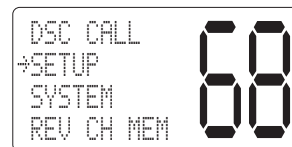
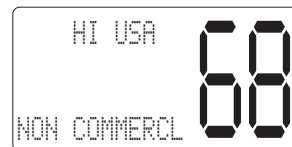

3. Rotate the **PUSH – SEL** knob to select CH TAG.

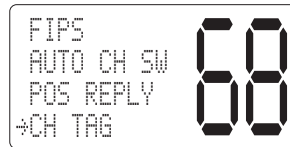

4. Press the **PUSH – SEL** knob. The following screen appears.
5. Press the **PUSH – SEL** knob to select the name you want to edit.

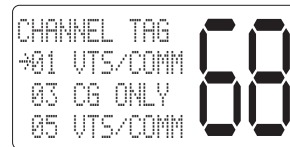

6. Press the **PUSH – SEL** to select EDIT.

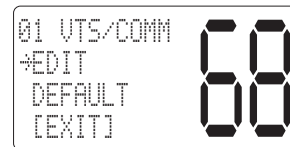

7. You can edit a displayed name. Rotate the **PUSH – SEL** knob clockwise or counterclockwise to select a character (letter, number, or symbol). The character will be entered when you press the **PUSH – SEL** knob, and the blinking digit moves to the right. Press **PUSH – SEL** knob for more than two seconds when you enter the last character.

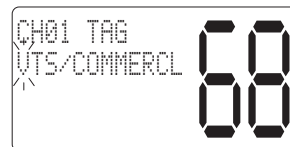

8. To save your changes, press the **PUSH – SEL** knob at YES.

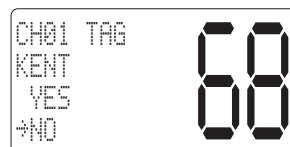

The **VHF600** returns to the following screen.



Defaulting a Channel Name

1. Press **MENU** briefly.
2. Press the **PUSH – SEL** knob at **SETUP**. The **SETUP** menu appears.
3. Rotate the **PUSH – SEL** knob to select **CH TAG**.
4. Press the **PUSH – SEL** knob. The following screen appears.
5. Press the **PUSH – SEL** knob at the channel you want to default.
6. Press the **PUSH – SEL** knob at **DEFAULT**.
7. Press the **PUSH – SEL** knob. The channel name is set as default.

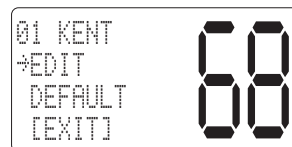
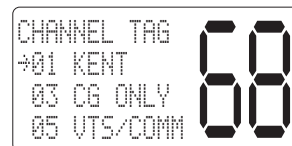
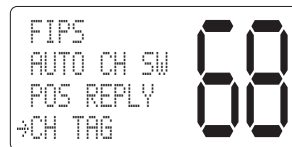
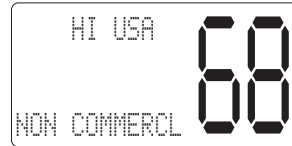

The **VHF600** returns to the following screen.

```

CHANNEL TAG
→01 VTS/COMM
  03 CG ONLY
  05 VTS/COMM
  68
  
```

Setting Up a U.I.C.

The **VHF600** can transmit and receive, **USA**, **International**, or **Canadian** frequencies. When you turn on the **VHF600**, USA channel mode is set as the default.

1. Press **MENU** briefly.
2. Press the **PUSH – SEL** knob at **SETUP**. The **SETUP** menu appears.
3. Rotate the **PUSH – SEL** knob to select **U. I. C.**
4. Press the **PUSH – SEL** knob. The following screen appears.
5. Rotate the **PUSH – SEL** knob to make your selection.

```

HI USA
NON COMMERCIAL
  68
  
```

```

DSC CALL
→SETUP
SYSTEM
REV CH MEM
  68
  
```

```

AUTO CH SW
POS REPLY
CH TAG
→U. I. C.
  68
  
```

```

U. I. C.
→USA
INT
CAN
  68
  
```

6. Press the **PUSH – SEL** knob. The **VHF600** changes to the selected U.I.C. display screen.

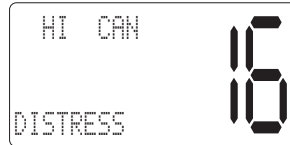

Note: The **VHF600** remembers the last channel selected in each mode. The first time you enter each mode, channel 16 is the default selected channel.

Setting Up a WHAM (Wireless Handheld Access Microphone)

You can use this feature to set up an optional wireless handheld access microphone for use with the radio.

Note: When you use the WHAM in addition to the **VHF600** wired mic, be sure to set the **BASE ID** for the WHAM to the same **BASE ID** as the **VHF600**. (Please refer to the *Owners Manual for the WHAM*).

1. Press **MENU** briefly.

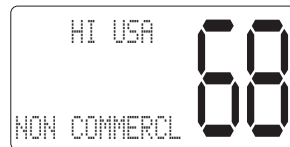

2. Press the **PUSH – SEL** knob at **SETUP**. The **SETUP** menu appears.

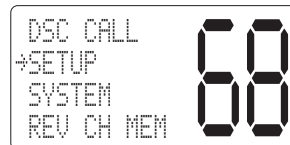

3. Rotate the **PUSH – SEL** knob to select **WHAM**.



4. Press the **PUSH – SEL** knob. The following screen appears.

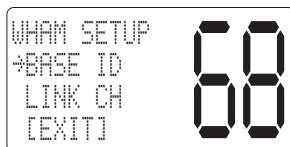

Setting a Base ID

A base ID lets your radio and a WHAM work together. You must set the same base ID for both the radio and the WHAM.

1. Press **MENU** briefly.
2. Press the **PUSH – SEL** knob at **SETUP**. The **SETUP** menu appears.
3. Press the **PUSH – SEL** knob at **WHAM**. The **WHAM** menu appears.
4. Press the **PUSH – SEL** knob at **BASE ID**. The following screen appears.
5. Rotate the **PUSH – SEL** knob clockwise to increase the number, or counterclockwise to decrease it. The number will be entered when you press the **PUSH – SEL** knob, and the blinking digit moves to the right. (You can select a base ID from 0000 to 9999.)
6. After you enter a base ID, a confirmation screen appears. Rotate the **PUSH – SEL** knob and then press **PUSH – SEL**.

Note: In order to confirm Base ID, it is necessary to shut off at once.

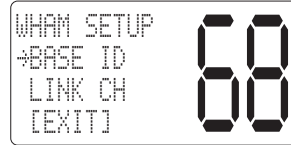
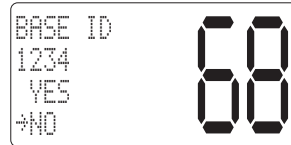
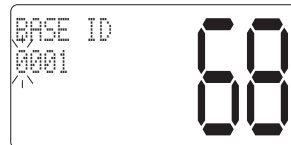
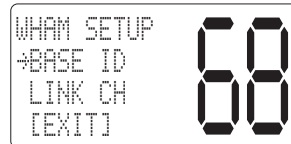
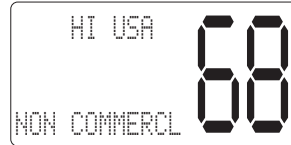

Changing the Link Channel

This feature lets you change the channel between the **VHF600** and the **WHAM** if you encounter interference.

1. Press **MENU** briefly.
2. Press the **PUSH – SEL** knob at **SETUP**. The **SETUP** menu appears.
3. Press the **PUSH – SEL** knob at **WHAM**. The **WHAM** menu appears.
4. Press the **PUSH – SEL** knob at **LINK CH**.
5. Rotate the **PUSH – SEL** knob clockwise to increase the number, or counterclockwise to decrease it. The number is entered when you press the **PUSH – SEL** knob. You can select a channel from 1 to 20.
6. After you enter the link channel, a confirmation screen appears. Rotate then press the **PUSH – SEL** knob.

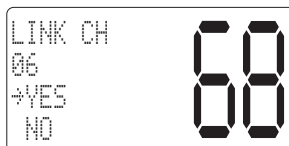
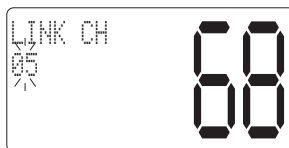
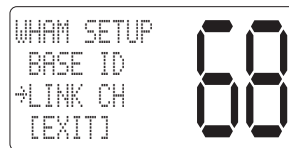
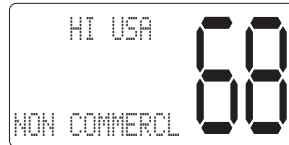

Setting Up a Group MMSI (Marine Mobile Service Identity)

This feature lets you specify a group MMSI. A group MMSI is a code that represents a group of specific vessels using DSC. When you specify a group MMSI, you can contact the vessels as a group and automatically switch to a desired channel.

1. Press **MENU** briefly.
2. Press the **PUSH – SEL** knob at **SETUP**. The **SETUP** menu appears.
3. Rotate the **PUSH – SEL** knob to select **GROUP MMSI**.
4. Press the **PUSH – SEL** knob. The following screen appears.
5. Enter the **GROUP MMSI** code by rotating the **PUSH – SEL** knob clockwise to increase the number, or counterclockwise to decrease it. The number will be entered when you press the **PUSH – SEL** knob, and the blinking digit moves to the right.
6. When you enter the final digit, a confirmation screen appears. Press the **PUSH – SEL** knob. The **VHF600** returns to the following screen.

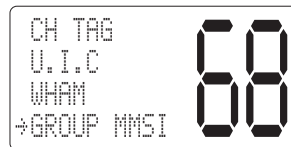
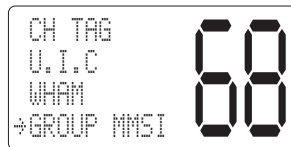
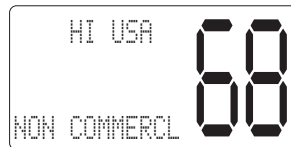

Setting Up a User MMSI

Important: Federal MMSI's are issued by the National Telecommunications and Information Administration. Non-Federal MMSI's are issued by the Federal Communications Commission (FCC). You will need to obtain a nine digit MMSI number and program it into the **VHF600**. The information obtained from the application is useful to the U.S. Coast Guard to help in search and rescue operations. To obtain an MMSI number, contact your authorized West Marine dealer or visit one of the following websites: <http://wireless.fcc.gov/marine/fctsht14.html> or www.boatus.com/mmsi/.

Important: You can only program your **VHF600** with a User MMSI number twice. After that, you must send your **VHF600** to West Marine for factory service.

This feature lets you program an MMSI for sending and receiving DSC calls.

1. Press **MENU** briefly.



2. Press the **PUSH – SEL** knob at **SETUP**. The **SETUP** menu appears.

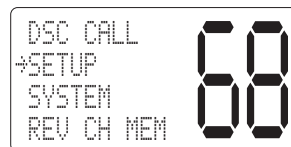

3. Rotate the **PUSH – SEL** knob to select **USER MMSI**.



4. Press the **PUSH – SEL** knob. The following screen appears.

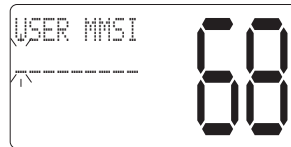

5. Enter the USER MMSI code by rotating the **PUSH – SEL** knob clockwise to increase the number, or counterclockwise to decrease it. The number will be entered when you press the **PUSH – SEL** knob, and the blinking digit moves to the right.

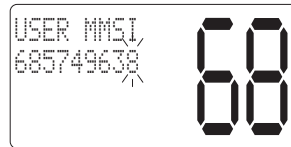

6. When you enter the final digit, the confirmation screen appears. Press the **PUSH – SEL** knob.

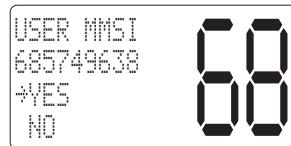

Setting Up The System

1. Press **MENU** briefly.
2. Press the **PUSH – SEL** knob at **SYSTEM**.

You can select any of the following system options.
To exit, select **EXIT**.

Setting the Contrast

You can select any of 10 contrast levels.

1. Press **MENU** briefly.
2. Press the **PUSH – SEL** knob at **SYSTEM**. The **SYSTEM** menu appears.
3. Press the **PUSH – SEL** knob to select **CONTRAST**.
4. Rotate the **PUSH – SEL** knob counterclockwise to increase the background brightness level.
5. When you find the most favorable brightness, press the **PUSH – SEL** knob. The **VHF600** returns to the following screen.

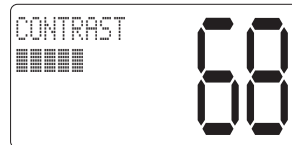
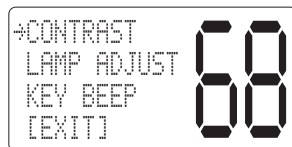
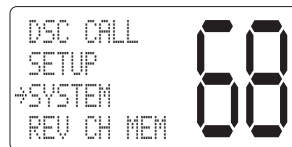

Setting the Backlight

1. Press **MENU** briefly.
2. Press the **PUSH – SEL** knob at **SYSTEM**. The **SYSTEM** menu appears.
3. Rotate the **PUSH – SEL** knob to select **LAMP ADJUST**.
4. Press the **PUSH – SEL** knob.
5. Rotate the **PUSH – SEL** knob to select the backlight brightness level. (Default is set to medium).
6. When you find the most favorable brightness, press the **PUSH – SEL** knob. The **VHF600** returns to the following screen.

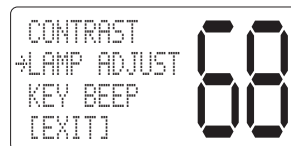
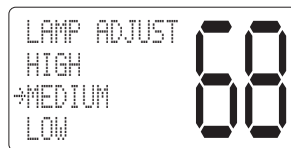
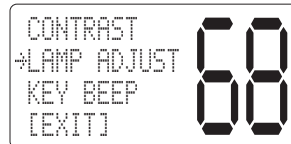
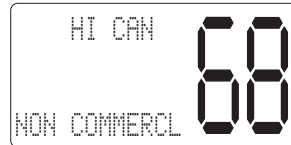

Setting the Key Beep

There are 10 volume levels.

1. Press **MENU** briefly.
2. Press the **PUSH – SEL** knob at **SYSTEM**. The **SYSTEM** menu appears.
3. Rotate the **PUSH – SEL** knob to select **KEY BEEP**.
4. Press the **PUSH – SEL** knob.
5. To adjust the key beep, rotate the **PUSH – SEL** knob clockwise to increase the volume or counterclockwise to decrease it.
6. When you find the most favorable volume, press the **PUSH – SEL** knob. The **VHF600** returns to the following screen.

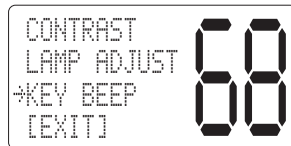
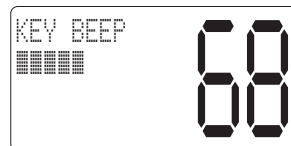
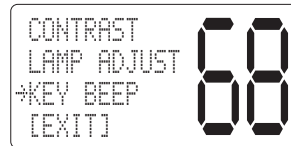

Reviewing Channel Memory

This feature lets you review all of the channels that have been programmed into the memory.

1. Press **MENU** briefly.



2. Press the **PUSH – SEL** knob at REV CH MEM. The MEMORY menu appears.



3. Rotate the **PUSH – SEL** knob to select the registered channel.

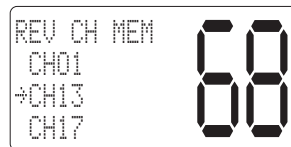

4. Press the **PUSH – SEL** knob. The selected channel appears.

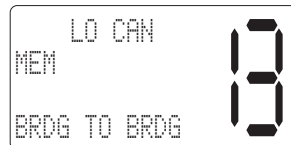

Note: When there are no channels registered in memory, an error tone sounds.

NMEA Technical Setup

Connecting a GPS Receiver to the Radio

This information will help you connect an external GPS receiver to the radio. Many GPS units have a setup menu to be able to configure the NMEA0183 serial data output. This output can be used to supply information to other devices on the vessel such as your radio, auto pilots, chart plotters, etc.

Set up a GPS receiver you want to use with your radio to these settings.

1. Baud Rate – Set the baud rate to 4800.
2. Data Bits – Set the data bits to 8.
3. Parity – Set the parity to None.
4. Stop Bits – Set the stop bits to 1.
5. GPRMC Command – This command is used by the radio and includes the UTC Time, Latitude, Longitude, Speed, Direction, and Date information.

Data Amplitude : Over 3.0V
Drive Capability : Over 10mA

Optional Accessories

- Flush mounting bracket for “in dash” installation.

Contact your West Marine store or dealer from whom you purchased the radio for information.

VHF FM Marine Radio Telephone Channel and Functions (USA Channels)

CHANNEL DESIG	FREQUENCY (MHz)		TYPE OF TRAFFIC	SHIP TO HIP	SHIP TO SHORE	CH Name	FULL NAME
	TRANSMIT	RECEIVE					
WX0	—	163.275	NOAA Weather	RX Only	RX Only	WEATHER10	WEATHER10
WX1	—	162.550	NOAA Weather	RX Only	RX Only	WEATHER1	WEATHER1
WX2	—	162.400	NOAA Weather	RX Only	RX Only	WEATHER2	WEATHER2
WX3	—	162.475	NOAA Weather	RX Only	RX Only	WEATHER3	WEATHER3
WX4	—	162.425	NOAA Weather	RX Only	RX Only	WEATHER4	WEATHER4
WX5	—	162.450	NOAA Weather	RX Only	RX Only	WEATHER5	WEATHER5
WX6	—	162.500	NOAA Weather	RX Only	RX Only	WEATHER6	WEATHER6
WX7	—	162.525	NOAA Weather	RX Only	RX Only	WEATHER7	WEATHER7
WX8	—	161.650	Can. Weather	RX Only	RX Only	WEATHER8	WEATHER8
WX9	—	161.775	Can. Weather	RX Only	RX Only	WEATHER9	WEATHER9
01	156.050	156.050	VTS	Yes	Yes	VTS/COMMERCL	VESSEL TRAFFIC SYSTEM/COMMERCIAL
02							
03	156.150	156.150	Port Ops	Yes	Yes	CG ONLY	COAST GUARD,GOVT ONLY
04							
05	156.250	156.250	VTS	Yes	Yes	VTS/COMMERCL	VESSEL TRAFFIC SYSTEM/COMMERCIAL
06	156.300	156.300	Safety	Yes	No	SAFETY	INTER-SHIP SAFETY
07	156.350	156.350	Com'l	Yes	Yes	COMMERCIAL	COMMERCIAL
08	156.400	156.400	Com'l	Yes	No	COMMERCIAL	COMMERCIAL
09	156.450	156.450	Com'l & Non Com'l	Yes	Yes	NON COMMERCL	NON COMMERCIAL
10	156.500	156.500	Com'l	Yes	Yes	COMMERCIAL	COMMERCIAL
11	156.550	156.550	Com'l	Yes	Yes	VSL TRAFFIC	VESSEL TRAFFIC SYSTEM
12	156.600	156.600	Port Ops	Yes	Yes	VSL TRAFFIC	VESSEL TRAFFIC SYSTEM
13	156.650	156.650	Navigational, TX 1W only	Yes	Yes	BRDG TO BRDG	BRIDGE TO BRIDGE
14	156.700	156.700	Port Ops	Yes	Yes	VSL TRAFFIC	VESSEL TRAFFIC SYSTEM
15	—	156.750	Environmental	RX Only	RX Only	ENVIRONMENTL	ENVIRONMENTAL
16	156.800	156.800	Safety Calling	Yes	Yes	DISTRESS	DISTRESS,SAFETY,CALLING
17	156.850	156.850	State Control	Yes	Yes	GOVERNMENT	GOVT MARITIME CONTROL
18	156.900	156.900	Com'l	Yes	Yes	COMMERCIAL	COMMERCIAL
19	156.950	156.950	Com'l	Yes	Yes	COMMERCIAL	COMMERCIAL
20	157.000	157.000	Port Ops, RX Duplex	Yes	Yes	PORT OPERATN	PORT OPERATION
21	157.050	157.050	Coast Guard	Yes	Yes	COAST GUARD	COAST GUARD ONLY
22	157.100	157.100	Coast Guard	Yes	Yes	COAST GUARD	COAST GUARD
23	157.150	157.150	Coast Guard	Yes	Yes	COAST GUARD	COAST GUARD ONLY
24	157.200	161.800	Public Corresp,Duplex	No	Yes	MAR OPERATOR	MARINE OPERATOR
25	157.250	161.850	Public Corresp,Duplex	No	Yes	MAR OPERATOR	MARINE OPERATOR
26	157.300	161.900	Public Corresp,Duplex	No	Yes	MAR OPERATOR	MARINE OPERATOR
27	157.350	161.950	Public Corresp,Duplex	No	Yes	MAR OPERATOR	MARINE OPERATOR
28	157.400	162.000	Public Corresp,Duplex	No	Yes	MAR OPERATOR	MARINE OPERATOR
60							
61	156.075	156.075				COAST GUARD	COAST GUARD
62							
63	156.175	156.175				VSL TRAFFIC	VESSEL TRAFFIC SYSTEM
64	156.225	156.225				COMMERCIAL	COMMERCIAL
65	156.275	156.275	Port Ops	Yes	Yes	PORT OPERATN	PORT OPERATION
66	156.325	156.325	Port Ops	Yes	Yes	PORT OPERATN	PORT OPERATION
67	156.375	156.375	Com'l, TX 1W only	Yes	No	BRDG TO BRDG	BRIDGE TO BRIDGE
68	156.425	156.425	Non Com'l	Yes	Yes	NON COMMERCL	NON COMMERCIAL
69	156.475	156.475	Non Com'l	Yes	Yes	NON COMMERCL	NON COMMERCIAL
70	156.525	156.525				DSC REC ONLY	DIGITAL SELECTIVE CALLING
71	156.575	156.575	Non Com'l	Yes	Yes	NON COMMERCL	NON COMMERCIAL
72	156.625	156.625	Non Com'l	Yes	No	NON COMMERCL	NON COMMERCIAL (SHIP-SHIP)
73	156.675	156.675	Port Ops	Yes	Yes	PORT OPERATN	PORT OPERATION
74	156.725	156.725	Port Ops	Yes	Yes	PORT OPERATN	PORT OPERATION
77	156.875	156.875	Port Ops	Yes	No	PORT OPERATN	PORT OPERATION (SHIP-SHIP)
78	156.925	156.925	Non Com'l	Yes	Yes	NON COMMERCL	NON COMMERCIAL
79	156.975	156.975	Com'l	Yes	Yes	COMMERCIAL	COMMERCIAL
80	157.025	157.025	Com'l	Yes	Yes	COMMERCIAL	COMMERCIAL
81	157.075	157.075	Coast Guard	Yes	Yes	COAST GUARD	COAST GUARD
82	157.125	157.125	US Govt Only	Yes	Yes	COAST GUARD	COAST GUARD
83	157.175	157.175	Coast Guard	Yes	Yes	GOVERNMENT	GOVERNMENT
84	157.225	161.825	Public Corresp,Duplex	No	Yes	MAR OPERATOR	MARINE OPERATOR
85	157.275	161.875	Public Corresp,Duplex	No	Yes	MAR OPERATOR	MARINE OPERATOR
86	157.325	161.925	Public Corresp,Duplex	No	Yes	MAR OPERATOR	MARINE OPERATOR
87	157.375	161.975	Public Corresp,Duplex	No	Yes	MAR OPERATOR	MARINE OPERATOR
88	157.425	157.425	Com'l	Yes	No	COMMERCIAL	COMMERCIAL (SHIP-SHIP)

VHF FM Marine Radio Telephone Channel and Functions (International Channels)

CHANNEL DESIG	FREQUENCY (MHz)		TYPE OF TRAFFIC	SHIP TO HIP	SHIP TO SHORE	CH Name	FULL NAME
	TRANSMIT	RECEIVE					
WX0	—	163.275	NOAA Weather	RX Only	RX Only	WEATHER10	WEATHER10
WX1	—	162.550	NOAA Weather	RX Only	RX Only	WEATHER1	WEATHER1
WX2	—	162.400	NOAA Weather	RX Only	RX Only	WEATHER2	WEATHER2
WX3	—	162.475	NOAA Weather	RX Only	RX Only	WEATHER3	WEATHER3
WX4	—	162.425	NOAA Weather	RX Only	RX Only	WEATHER4	WEATHER4
WX5	—	162.450	NOAA Weather	RX Only	RX Only	WEATHER5	WEATHER5
WX6	—	162.500	NOAA Weather	RX Only	RX Only	WEATHER6	WEATHER6
WX7	—	162.525	NOAA Weather	RX Only	RX Only	WEATHER7	WEATHER7
WX8	—	161.650	Can. Weather	RX Only	RX Only	WEATHER8	WEATHER8
WX9	—	161.775	Can. Weather	RX Only	RX Only	WEATHER9	WEATHER9
01	156.050	160.650	VTs,Duplex	Yes	Yes	MAR OPERATOR	MARINE OPERATOR
02	156.100	160.700	Port Ops,Duplex	Yes	Yes	MAR OPERATOR	MARINE OPERATOR
03	156.150	160.750	Port Ops,Duplex	Yes	Yes	MAR OPERATOR	MARINE OPERATOR
04	156.200	160.800	Port Ops,Duplex	Yes	Yes	MAR OPERATOR	MARINE OPERATOR
05	156.250	160.850	VTs,Duplex	Yes	Yes	MAR OPERATOR	MARINE OPERATOR
06	156.300	156.300	Safety	Yes	No	SAFETY	INTER-SHIP SAFETY
07	156.350	160.950	Com',Duplex	Yes	Yes	MAR OPERATOR	MARINE OPERATOR
08	156.400	156.400	Com'l	Yes	No	COMMERCIAL	COMMERCIAL (SHIP-SHIP)
09	156.450	156.450	Com'l & Non Com'l	Yes	Yes	CALLING	BOATER CALLING CHANNEL
10	156.500	156.500	Com'l	Yes	Yes	COMMERCIAL	COMMERCIAL
11	156.550	156.550	Com'l	Yes	Yes	VSL TRAFFIC	VESSEL TRAFFIC SYSTEM
12	156.600	156.600	Port Ops	Yes	Yes	VSL TRAFFIC	VESSEL TRAFFIC SYSTEM
13	156.650	156.650	Navigational	Yes	Yes	BRDG TO BRDG	BRIDGE TO BRIDGE
14	156.700	156.700	Port Ops	Yes	Yes	VSL TRAFFIC	VESSEL TRAFFIC SYSTEM
15	156.750	156.750	Environmental	Yes	Yes	ENVIRONMENTL	ENVIRONMENTAL
16	156.800	156.800	Safety Calling	Yes	Yes	DISTRESS	DISTRESS,SAFETY,CALLING
17	156.850	156.850	State Control	Yes	Yes	GOVERNMENT	GOVT MARITIME CONTROL
18	156.900	161.500	Com'l,Duplex	Yes	Yes	PORT OPERATN	PORT OPERATION
19	156.950	161.550	Com'l,Duplex	Yes	Yes	COMMERCIAL	COMMERCIAL
20	157.000	161.600	Port Ops,Duplex	Yes	Yes	PORT OPERATN	PORT OPERATION
21	157.050	161.650	Coast Guard,Duplex	Yes	Yes	PORT OPERATN	PORT OPERATION
22	157.100	161.700	Coast Guard,Duplex	Yes	Yes	PORT OPERATN	PORT OPERATION
23	157.150	161.750	Coast Guard,Duplex	Yes	Yes	MAR OPERATOR	MARINE OPERATOR
24	157.200	161.800	Public Corresp,Duplex	No	Yes	MAR OPERATOR	MARINE OPERATOR
25	157.250	161.850	Public Corresp,Duplex	No	Yes	MAR OPERATOR	MARINE OPERATOR
26	157.300	161.900	Public Corresp,Duplex	No	Yes	MAR OPERATOR	MARINE OPERATOR
27	157.350	161.950	Public Corresp,Duplex	No	Yes	MAR OPERATOR	MARINE OPERATOR
28	157.400	162.000	Public Corresp,Duplex	No	Yes	MAR OPERATOR	MARINE OPERATOR
60	156.025	160.625	Duplex			MAR OPERATOR	MARINE OPERATOR
61	156.075	160.675	Duplex			MAR OPERATOR	MARINE OPERATOR
62	156.125	160.725	Duplex			MAR OPERATOR	MARINE OPERATOR
63	156.175	160.775	Duplex			MAR OPERATOR	MARINE OPERATOR
64	156.225	160.825	Duplex			MAR OPERATOR	MARINE OPERATOR
65	156.275	160.875	Port Ops,Duplex	Yes		MAR OPERATOR	MARINE OPERATOR
66	156.325	160.925	Port Ops,Duplex	Yes	Yes	MAR OPERATOR	MARINE OPERATOR
67	156.375	156.375	Com'l	Yes	No	BRDG TO BRDG	BRIDGE TO BRIDGE
68	156.425	156.425	Non Com'l	Yes	Yes	NON COMMERCL	NON COMMERCIAL
69	156.475	156.475	Non Com'l	Yes	Yes	NON COMMERCL	NON COMMERCIAL
70	156.525	156.525				DSC REC ONLY	DIGITAL SELECTIVE CALLING
71	156.575	156.575	Non Com'l	Yes	Yes	NON COMMERCL	NON COMMERCIAL
72	156.625	156.625	Non Com'l	Yes	No	NON COMMERCL	NON COMMERCIAL
73	156.675	156.675	Port Ops	Yes	Yes	PORT OPERATN	PORT OPERATION
74	156.725	156.725	Port Ops	Yes	Yes	PORT OPERATN	PORT OPERATION
77	156.875	156.875	Port Ops	Yes	No	PORT OPERATN	PORT OPERATION (SHIP-SHIP)
78	156.925	161.525	Non Com'l,Duplex	Yes	Yes	PORT OPERATN	PORT OPERATION
79	156.975	161.575	Com'l,Duplex	Yes	Yes	PORT OPERATN	PORT OPERATION
80	157.025	161.625	Com'l,Duplex	Yes	Yes	PORT OPERATN	PORT OPERATION
81	157.075	161.675	Coast Guard,Duplex	Yes	Yes	PORT OPERATN	PORT OPERATION
82	157.125	161.725	US Govt Only,Duplex	Yes	Yes	PORT OPERATN	PORT OPERATION
83	157.175	161.775	Coast Guard,Duplex	Yes	Yes	PORT OPERATN	PORT OPERATION
84	157.225	161.825	Public Corresp,Duplex	No	Yes	MAR OPERATOR	MARINE OPERATOR
85	157.275	161.875	Public Corresp,Duplex	No	Yes	MAR OPERATOR	MARINE OPERATOR
86	157.325	161.925	Public Corresp,Duplex	No	Yes	MAR OPERATOR	MARINE OPERATOR
87	157.375	161.975	Public Corresp,Duplex	No	Yes	MAR OPERATOR	MARINE OPERATOR
88	157.425	162.025	Com'l,Duplex	Yes	No	MAR OPERATOR	MARINE OPERATOR

VHF FM Marine Radio Telephone Channel and Functions (Canadian Channels)

CHANNEL DESIG	FREQUENCY (MHz)		TYPE OF TRAFFIC	SHIP TO HIP	SHIP TO SHORE	CH Name	FULL NAME
	TRANSMIT	RECEIVE					
WX0	—	163.275	NOAA Weather	RX Only	RX Only	WEATHER10	WEATHER10
WX1	—	162.550	NOAA Weather	RX Only	RX Only	WEATHER1	WEATHER1
WX2	—	162.400	NOAA Weather	RX Only	RX Only	WEATHER2	WEATHER2
WX3	—	162.475	NOAA Weather	RX Only	RX Only	WEATHER3	WEATHER3
WX4	—	162.425	NOAA Weather	RX Only	RX Only	WEATHER4	WEATHER4
WX5	—	162.450	NOAA Weather	RX Only	RX Only	WEATHER5	WEATHER5
WX6	—	162.500	NOAA Weather	RX Only	RX Only	WEATHER6	WEATHER6
WX7	—	162.525	NOAA Weather	RX Only	RX Only	WEATHER7	WEATHER7
WX8	—	161.650	Can. Weather	RX Only	RX Only	WEATHER8	WEATHER8
WX9	—	161.775	Can. Weather	RX Only	RX Only	WEATHER9	WEATHER9
01	156.050	160.650	Duplex	Yes	Yes	MAR OPERATOR	MARINE OPERATOR
02	156.100	160.700	Duplex	Yes	Yes	MAR OPERATOR	MARINE OPERATOR
03	156.150	160.750	Duplex	Yes	Yes	MAR OPERATOR	MARINE OPERATOR
04	156.200	156.200		Yes	Yes	COAST GUARD	COAST GUARD
05	156.250	156.250		Yes	Yes	VSL TRAFFIC	VESSEL TRAFFIC SYSTEM
06	156.300	156.300		Yes	No	SAFETY	INTER-SHIP SAFETY
07	156.350	156.350		Yes	Yes	COMMERCIAL	COMMERCIAL
08	156.400	156.400		Yes	No	COMMERCIAL	COMMERCIAL
09	156.450	156.450		Yes	Yes	CALLING	BOATER CALLING CHANNEL
10	156.500	156.500		Yes	Yes	COMMERCIAL	COMMERCIAL
11	156.550	156.550		Yes	Yes	VSL TRAFFIC	VESSEL TRAFFIC SYSTEM
12	156.600	156.600		Yes	Yes	VSL TRAFFIC	VESSEL TRAFFIC SYSTEM
13	156.650	156.650	1W	Yes	Yes	BRDG TO BRDG	BRIDGE TO BRIDGE
14	156.700	156.700		Yes	Yes	VSL TRAFFIC	VESSEL TRAFFIC SYSTEM
15	156.750	156.750	1W	Yes	Yes	ENVIRONMENTL	ENVIRONMENTAL
16	156.800	156.800		Yes	Yes	DISTRESS	DISTRESS,SAFETY,CALLING
17	156.850	156.850	1W	Yes	Yes	STATE CNTRL	STATE CONTROL
18	156.900	156.900		Yes	Yes	COMMERCIAL	COMMERCIAL
19	156.950	156.950		Yes	Yes	COAST GUARD	CANADIAN COAST GUARD
20	157.000	161.600	Duplex, 1W	Yes	Yes	PORT OPERATN	PORT OPERATION
21	157.050	157.050		Yes	Yes	COAST GUARD	COAST GUARD
22	157.100	157.100		Yes	Yes	COAST GUARD	COAST GUARD
23	157.150	161.750	Duplex	Yes	Yes	COAST GUARD	COAST GUARD
24	157.200	161.800	Duplex	No	Yes	MAR OPERATOR	MARINE OPERATOR
25	157.250	161.850	Duplex	No	Yes	MAR OPERATOR	MARINE OPERATOR
26	157.300	161.900	Duplex	No	Yes	MAR OPERATOR	MARINE OPERATOR
27	157.350	161.950	Duplex	No	Yes	MAR OPERATOR	MARINE OPERATOR
28	157.400	162.000	Duplex	No	Yes	MAR OPERATOR	MARINE OPERATOR
60	156.025	160.625	Duplex			MAR OPERATOR	MARINE OPERATOR
61	156.075	156.075				COAST GUARD	COAST GUARD
62	156.125	156.125				COAST GUARD	COAST GUARD
63	—	—					
64	156.225	156.225	Simplex			MAR OPERATOR	MARINE OPERATOR
65	156.275	156.275		Yes	Yes	SRCH RESCUE	SEARCH AND RESCUE
66	156.325	156.325		Yes	Yes	PORT OPERATN	PORT OPERATION
67	156.375	156.375		Yes	No	BRDG TO BRDG	BRIDGE TO BRIDGE
68	156.425	156.425		Yes	Yes	NON COMMERCL	NON COMMERCIAL
69	156.475	156.475		Yes	Yes	NON COMMERCL	NON COMMERCIAL
70	156.525	156.525				DSC REC ONLY	DIGITAL SELECTIVE CALLING
71	156.575	156.575		Yes	Yes	NON COMMERCL	NON COMMERCIAL
72	156.625	156.625		Yes	No	NON COMMERCL	NON COMMERCIAL
73	156.675	156.675		Yes	Ye	PORT OPERATN	PORT OPERATION
74	156.725	156.725		Yes	Ye	PORT OPERATN	PORT OPERATION
77	156.875	156.875		Yes	No	PORT OPERATN	PORT OPERATION
78	156.925	156.925		Yes	Yes	INTER SHIP	INTER SHIP
79	156.975	156.975		Yes	Yes	INTER SHIP	INTER SHIP
80	157.025	157.025		Yes	Yes	INTER SHIP	INTER SHIP
81	157.075	157.075		Yes	Yes	COAST GUARD	COAST GUARD
82	157.125	157.125		Yes	Yes	COAST GUARD	COAST GUARD
83	157.175	157.175		Yes	Yes	COAST GUARD	COAST GUARD
84	157.225	161.825	Duplex	No	Yes	MAR OPERATOR	MARINE OPERATOR
85	157.275	161.875	Duplex	No	Yes	MAR OPERATOR	MARINE OPERATOR
86	157.325	161.925	Duplex	No	Yes	MAR OPERATOR	MARINE OPERATOR
87	157.375	161.975	Duplex	No	Yes	MAR OPERATOR	MARINE OPERATOR
88	157.425	162.025	Duplex	Yes	No	MAR OPERATOR	MARINE OPERATOR

NWR-SAME EVENT CODE

Event Code	Standard	EVENT LEVEL (Siren Type)				Radio Status Display
		Warning	Watch	Statement	Test	
Emergency Action Notification	EAN	0				EMG NOTIFY
Emergency Action Termination	EAT	0				EMG END
National Information Center	NIC	0				NATION INFO
Tornado Warning #	TOW (or TOR)	0				TORNADO
Severe Thunderstorm Warning #	SVW (or SVR)	0				THUNDERSTORM
Flash Flood Warning	FFW	0				FLASH FLOOD
Flood Warning	FLW	0				FLOOD
Winter Storm Warning	WSW	0				WINTER STORM
Blizzard Warning	BZW	0				BLIZZARD
High Wind/Dust Storm Warning	HWW	0				HIGH WIND
Radiological Hazard Warning	RHW	0				RADIOLOGICAL
Civil Danger Warning	CDW	0				CIVILDANGER
Local Area Emergency	LAE	0				LOCAL EMG
Hazardous Material Warning	HMW	0				HAZARDOUS
Civil Emergency Message	CEM	0				CIVIL EMG
Immediate Evacuation Warning	IEW	0				EVACUATION
Immediate Evacuation Notice	EVI	0				EVACUATENOTE
Law Enforcement Warning	LEW	0				LAW ENFORCE
Fire Warning	FRW	0				FIRE
Hurricane/Tropical Storm Warning	HUW	0				HURRICANE
Tsunami Warning	TSW	0				TSUNAMI
Coastal Flood Warning	CFW	0				COAST FLOOD
Special Marine Warning	SMW	0				SPECIAL MRN
Avalanche Warning	AVW	0				AVALANCHE
Volcano Warning	VOW	0				VOLCANO
Shelter In Place Warning	SPW	0				SHELTER
Child Abduction Emergency	CAE	0				CHILD EMG
Dust Storm Warning	DSW	0				DUST STORM
Earthquake Warning	EQW	0				EARTHQUAKE
911 Telephone Outage Emergency	TOE	0				911 OUTAGE
Nuclear Power Plant Warning	NUW	0				NUCLEAR
Tropical Storm Warning	TRW	0				TROPIC STORM
Nuclear Power Plant Warning	NPW	0				NUCLEAR
Nuclear Power Plant Warning	NPP	0				NUCLEAR
Dam Break Warning	DBW	0				DAM BREAK
Civil Danger Watch	CDA		0			CIVIL DANGER
Radiological Hazard Watch	RHA		0			RADIOLOGICAL
Hazardous Material Watch	HMA		0			HAZARDOUS
Winter Storm Watch	WSA		0			WINTER STORM
High Wind/Dust Storm Watch	HWA		0			HIGH WIND
Tornado Watch	TOA		0			TORNADO
Severe Thunderstorm Watch	SVA		0			THUNDERSTORM
Flash Flood Watch	FFA		0			FLASH FLOOD
Flood Watch	FLA		0			FLOOD
Hurricane/Tropical Storm Watch	HUA		0			HURRICANE
Tsunami Watch	TSA		0			TSUNAMI
Coastal Flood Watch	CFA		0			COAST FLOOD
Avalanche Watch	AVA		0			AVALANCHE
Volcano Watch	VOA		0			VOLCANO
Tropical Storm Watch	TRA		0			TROPIC STORM
Dust Storm Watch	DSA		0			DUST STORM
Earthquake Watch	EQA		0			EARTHQUAKE
Severe Weather Statement	SVS			0		SEVERE WX
Special Weather Statement	SPS			0		SPECIAL WX
Flash Flood Statement	FFS			0		FLASH FLOOD
Flood Statement	FLS			0		FLOOD
Hurricane Statement	HLS			0		HURRICANE
Administrative Message	ADR			0		ADMIN MSG
Network Message Notification	NMN			0		NETWORK MSG
Missing Child Statement	MIS			0		MISS CHILD
School Closing Statement	SCS			0		SCHOOL CLOSE
National Periodic Test	NPT				0	NATIONPERIOD
Required Monthly Test	RMT				0	MONTHLY
Required Weekly Test	RWT				0	WEEKLY
Nuclear Power Plant Test Message	NPM				0	NUCLEAR
System Demonstration/Practice	DMO					SYSTEM DEMO
NATIONAL HAZARD WARNING	NHW	0				NATIONHAZARD
UNKNOWN EMERGENCY TUNE TV	**E	0				UNKNOWN TV
UNKNOWN WARNING TUNE TV	**W	0				UNKNOWN TV
UNKNOWN WATCH TUNE TV	**A		0			UNKNOWN TV
UNKNOWN STATEMENT TUNE TV	**S			0		UNKNOWN TV

Specifications

General

Channels	: Transmit 55 Receive 80 Marine/10 Weather
Controls	: On-Off/Volume, Squelch
Status Indicators	: TX (Transmit), TRI (Triple Watch), HI (High), LO (Low), USA, CAN, INT, ALT, MEM, WX and Channel Display
Channel Display	: LCD (Full Dot Matrix)
Selector Switch	: Channel Selector switch
Buttons	: WX, 16/9, SCAN, H/L, HAIL, MENU, +, -, and DISTRESS
Connectors	: Antenna, Remote, ACC, and DC power
Size	: H76.8 mm x W182 mm x L171.5 mm (without Heat Sink) H3.02 inches x W7.17 inches x L6.75 inches
Weight	: 1.15kg / 2.54 lbs / 37.1 oz
Supply Voltage	: 13.8V DC negative ground
Standard Accessories	: Mounting bracket and hardware, DC power cord, microphone hanger, spare fuse, ACC Cable
Antenna Impedance	: 50 Ω nominal
Microphone	: Rugged 2 k Ω condenser mic element with coiled cord
Speaker	: 1.82 inch, 8 Ω
Operating Temperature Range	: -20 °C to + 50 °C (-4 °F to +122 °F)
Shock and Vibration	: Meets or exceeds EIA standards, RS152B and RS204C
FCC Approvals	: Type accepted under part 80 of the Rules; meets Great Lakes Agreement and party boat requirements

Transmitter

Power Output	: 1 watt or 25 watt (switch selectable)
Power Requirement	: Not rated on LO, 25 watts output: 4.5A@13.8V DC
Modulation	: FM ± 5 kHz deviation (FCC designator F3E)
Hum and Noise Signal-to-Noise	: 45 dB@1 kHz with 3 kHz deviation with 1000 Hz modulating frequency (nominal)
Audio Distortion	: Less than 8% with 3 kHz deviation with 1000 Hz modulating frequency
Spurious Suppression	: -25 dBm @ Hi, -25 dBm @ Lo
Output Power Stabilization	: Built-in automatic level control (ALC)
Frequency Range	: 156 to 158 MHz
Frequency Stability	: ± 10 ppm @ -20°C to + 50°C

Receiver

Frequency Range	: 156 to 163 MHz
Sensitivity	: 0.25 μ V for 12 dB SINAD
Circuit	: Dual Conversion Super Heterodyne PLL
Squelch Sensitivity	: 0.6 μ V Threshold
Spurious Response	: 90 dB
Adjacent Channel Selectivity	: 72 dB @ ± 25 kHz
Audio Output Power	: 3.0 watts (10% Distortion)
Power Requirement	: 400 mA @ 13.8V DC squelched, 0.7A @ 13.8V DC at maximum audio output
IF Frequencies	: 1st 21.4 MHz, 2nd -455 kHz

Troubleshooting

In the event that the radio fails to perform, or needs servicing, please send the radio directly to our Electronics Repair Center in Hollister, CA. Be sure to include your return mailing information and detailed accounting of the problems experienced and/or the service requested.

West Marine
 Electronics Repair Center
 2395 Bert Court
 Hollister, CA 95023
 Please call us at 831-761-4205

SYMPTOM	CAUSE	REMEDY
The radio does not turn on.	No or low voltage.	Make sure the radio is receiving power.
When PTT is pressed, TX appears and other radios hear a "click" but cannot hear you transmit.	Bad mic element.	Call West Marine for repair information.
While scanning, the radio stops on a particular channel all of the time.	A source of noise is nearby.	Eliminate the source of the noise or delete the channel from the radio.
You hear noise that the squelch will not eliminate.	An external noise is being generated by another device.	Either turn off the offending device or contact the device's manufacturer.

SYMPTOM	CAUSE	REMEDY
You want to talk to another radio user, but you cannot hear them.	You and the other user might be using different country codes.	Make sure that you are both using the same Country mode (USA, International, or Canadian). Several channels have the same numeric designation, but are either on different frequencies or the channels are used for different purposes. Channel 16 (the Distress, Safety, and Calling channel) is the same on all three bands.
You cannot change the transmit power setting.	You are on a channel which is limited to 1 watt transmit power (e.g. Ch. 13) or you are on a "receive only" channel such as a weather channel.	Change to an unrestricted TX/RX channel.
The SCAN key does not start the scan function.	CAUSE 1: No channels are in the scan memory. CAUSE 2: The squelch is not adjusted correctly.	REMEDY 1: Enter channels into the scan memory (See "Entering Channel Numbers into Memory Scan" on page 15). REMEDY 2: Adjust the squelch to the point that background noise just disappears.
You can hear transmissions, but the other radio cannot hear you.	The transmit power is set to low.	Press H/L to select a higher transmit power setting.

Care and Maintenance

Your **VHF600** is a precision electronic instrument and you should treat it accordingly. Due to its rugged design, very little maintenance is required. However, a few precautions should be observed:

- If the antenna has been damaged, you should not transmit except in the case of an emergency. A defective antenna may cause damage to your radio.
- You are responsible for continued FCC technical compliance of your radio.

West Marine
Electronics Repair Center
2395 Bert Court
Hollister, CA 95023
Please call us at 831-761-4205

Note

Three Year Limited Warranty

WARRANTOR: WEST MARINE AMERICA CORPORATION ("West Marine")

ELEMENTS OF WARRANTY: West Marine warrants, for three years, to the original retail owner, this West Marine Product to be free from defects in materials and craftsmanship with only the limitations or exclusions set out below.

WARRANTY DURATION: This warranty to the original user shall terminate and be of no further effect 36 months after the date of original retail sale. The warranty is invalid if the Product is (A) damaged or not maintained as reasonable or necessary, (B) modified, altered, or used as part of any conversion kits, subassemblies, or any configurations not sold by West Marine, (C) improperly installed, (D) serviced or repaired by someone other than an authorized West Marine service center for a defect or malfunction covered by this warranty, (E) used in any conjunction with equipment or parts or as part of any system not manufactured by West Marine, or (F) installed or programmed by anyone other than as detailed by the Operating Guide for this product.

STATEMENT OF REMEDY: In the event that the product does not conform to this warranty at any time while this warranty is in effect, warrantor will repair the defect and return it to you without charge for parts, service, or any other cost (except shipping and handling) incurred by warrantor or its representatives in connection with the performance of this warranty. THE LIMITED WARRANTY SET FORTH ABOVE IS THE SOLE AND ENTIRE WARRANTY PERTAINING TO THE PRODUCT AND IS IN LIEU OF AND EXCLUDES ALL OTHER WARRANTIES OF ANY NATURE WHATSOEVER, WHETHER EXPRESS, IMPLIED OR ARISING BY OPERATION OF LAW, INCLUDING, BUT NOT LIMITED TO ANY IMPLIED WARRANTIES OF MERCHANTABILITY OR FITNESS FOR A PARTICULAR PURPOSE. THIS WARRANTY DOES NOT COVER OR PROVIDE FOR THE REIMBURSEMENT OR PAYMENT OF INCIDENTAL OR CONSEQUENTIAL DAMAGES. Some states do not allow this exclusion or limitation of incidental or consequential damages so the above limitation or exclusion may not apply to you.

LEGAL REMEDIES: This warranty gives you specific legal rights, and you may also have other rights which vary from state to state. This warranty is void outside the United States of America.

PROCEDURE FOR OBTAINING PERFORMANCE OF WARRANTY: If, after following the instructions in this Operating Guide you are certain that the Product is defective, pack the Product carefully (preferably in its original packaging). Include evidence of original purchase and a note describing the defect that has caused you to return it. The Product should be shipped freight prepaid, by traceable means, or delivered, to warrantor at:

West Marine
P.O. Box 50070
Watsonville, CA 95077-0070

QUESTIONS?

*Contact your local
West Marine store*

Call 1-800-BOATING

*Contact us at
www.westmarine.com*

 **West Marine®**
Watsonville, CA

Made in China
Fabriqué en China
Hecho en China

Printed in China
UTZZ01921ZZ